



City Council AGENDA

Tuesday, April 21, 2026 - 7:00 PM

Regular Meeting
Agawam Senior Center
954 Main Street
Agawam, MA 01001

- A. ROLL CALL
- B. MOMENT OF SILENCE AND PLEDGE OF ALLEGIANCE
- C. CITIZEN'S SPEAK TIME
- D. MINUTES
 - 1) Regular Council Meeting – **April 6, 2026**
- E. DECLARATION OF COUNCIL PRESIDENT
- F. PRESENTATION OF RESOLUTIONS
 - 1) **TR-2026-16** - A Resolution authorizing the Adoption of Orders of Taking for the Intersection Improvement Project at Cooper Street, Suffield Street and Rowley Street under the authority of Massachusetts General Laws Chapter 40 §14 and Chapter 79 for the purpose of reconstructing the intersection of Cooper Street, Suffield Street and Rowley Street (Sponsored by Mayor Johnson)
 - 2) **TR-2026-17** - A Resolution to appropriate and authorize borrowing in the amount of Two Million Five Hundred Seventy-Seven Thousand Three Hundred Ninety-Eight (\$2,577,398.00) Dollars for the purchase of two fire engine pump trucks for the Agawam Fire Department (Sponsored by Mayor Johnson) (**Referred to Finance Committee**)
 - 3) **TR-2026-18** - A Resolution confirming the reappointment of **Henry A. Kozloski**, 102 Meadow Street, Agawam to the Community Preservation Act Committee to a term expiring April 30, 2029 (Sponsored by Mayor Johnson)
 - 4) **TR-2026-19** - A Resolution confirming the reappointment of **Frank DeStefano**, 918 Shoemaker Lane, Feeding Hills to the Community Preservation Act Committee to a term expiring April 30, 2029 (Sponsored by Mayor Johnson)
 - 5) **TR-2026-21** - A Resolution accepting a grant from the Executive Office of Public Safety and Security and the Department of Fire Services in the amount of Eighteen Thousand Seven Hundred Sixty (\$18,760.00) Dollars to the Agawam Fire Department pursuant to Massachusetts General

Laws Chapter 44, Section 53(A) (Sponsored by Mayor Johnson) **(Referred to Finance Committee)**

- 6) **TR-2026-22** - A Resolution appropriating and authorizing the expenditure of Community Preservation Funds for Field Irrigation at the Agawam Junior High School (CPA) **(Referred to Community Relations Committee)**
- 7) **TR-2026-23** - A Resolution appropriating and authorizing the expenditure of Community Preservation funds for removal of bittersweet and habitat restoration (CPA) **(Referred to Community Relations Committee)**
- 8) **TR-2026-24** - A Resolution Authorizing the Reservation and appropriation of funds from the Community Preservation Fund (CPA) **(Referred to Community Relations Committee)**
- 9) **TR-2026-25** - A Resolution accepting a grant from the Commonwealth of Massachusetts Executive Office for administration and finance to the Town of Agawam for direct pay tax assistance pursuant to Massachusetts General Laws Chapter 44, Section 53a (Sponsored by Mayor Johnson) **(Referred to Finance Committee)**
- 10) **TR-2026-26** - A Resolution to appropriate funds for the successor Collective Bargaining Agreement by and between the Agawam Police Patrolmen's Association and the Town of Agawam (Sponsored by Mayor Johnson)
- 11) **TR-2026-27** - A Resolution to appropriate Eighty Thousand (\$80,000.00) Dollars from the Municipal Golf Stabilization Fund to fund Agawam Municipal Golf Course operations accounts (Sponsored by Mayor Johnson) **(Referred to Finance Committee)**

G. ELECTIONS

H. PUBLIC HEARINGS

- 1) **TR-2026-20** - A Resolution adopting the Fiscal Year 2027 to Fiscal Year 2031 Capital Improvement Plan (Sponsored by Mayor Johnson) –**Public Hearing date set for May 4, 2026**
- 2) **ZC-2026-2** - Petition for zone change by Charlie's Garden Park, L.L.C. for property located at 1399 Suffield Street, Agawam, Hampden County, Massachusetts (Assessor Parcel I3-2-7) and property known as Parcel 2 Suffield Street, Agawam, Hampden County, Massachusetts (Assessor Parcel I3-2-31) **(Referred to Legislative Committee) –Public Hearing Date set for May 18, 2026**

I. OLD BUSINESS

- 1) **TO-2026-4** - Budgetary Transfer in the amount of \$99,070.00 from Line Items – Salary Reserve (#16605-57350) to Police Regular Permanent, Police Overtime, and Police Holiday accounts

J. NEW BUSINESS

- 1) **TR-2026-28** - A Resolution relative to the approval of the Western Hampden District Veterans Services Inter-Municipal Agreement between the City of Agawam and the Towns of Granville, Russell, Southwick, and Tolland (Sponsored by Mayor Johnson)

- 2) **TR-2026-29** - A Resolution Supporting House Bill 5290 and Senate Bill 2285 which establishes "One Touch Make Ready Applications" in the Commonwealth of Massachusetts (Sponsored by Councilors Hendrickson and Sandlin)
- 3) **TR-2026-30** - A Resolution to appropriate funds for the successor collective bargaining agreement by and between the Agawam Department of Public Works Employees' Association and the Town of Agawam (Sponsored by Mayor Johnson)
- 4) **TO-2026-5** - Budgetary Transfer of \$69,195.00 from Salary Reserve accounts to various Department of Public Works accounts

K. ANY OTHER MATTER THAT MAY LEGALLY COME BEFORE THE CITY COUNCIL

L. ADJOURNMENT

Please note that this meeting can be viewed live on Channel 15 (standard definition) or Channel 1074 (high definition) and will also be live-streamed on the town's website (www.agawam.ma.us)

A RESOLUTION AUTHORIZING THE ADOPTION OF ORDERS OF TAKING FOR THE INTERSECTION IMPROVEMENT PROJECT AT COOPER STREET, SUFFIELD STREET AND ROWLEY STREET UNDER THE AUTHORITY OF MASSACHUSETTS GENERAL LAWS CHAPTER 40 §14 AND CHAPTER 79 FOR THE PURPOSE OF RECONSTRUCTING THE INTERESECTION OF COOPER STREET, SUFFIELD STREET AND ROWLEY STREET

(Sponsored by Christopher C. Johnson, Mayor)

WHEREAS, this Resolution authorizes the taking of interests in land necessary to allow for the construction, maintenance and improvements for the reconstruction of the intersection located at Cooper Street, Suffield Street and Rowley Street; and

WHEREAS, it is necessary to take, by eminent domain, certain real estate not owned by the Town of Agawam in both fee and easement (see Exhibits 1 through 5 for a more detailed description) pursuant to Massachusetts General Laws Chapter 40 §14 and Chapter 79 in order to complete the reconstruction of the intersection located at Cooper Street, Suffield Street and Rowley Street; and

WHEREAS, the interests in fee and easements being taken by the Town of Agawam for the reconstruction of the intersection located at Cooper Street, Suffield Street and Rowley Street will result in damages being assessed to the owners of the parcels so taken in the total amount of Six Thousand Nine Hundred Twenty and 00/100 (\$6,920.00) Dollars; and

WHEREAS, the Agawam City Council has appropriated funds for said takings as part of its resolution to accept Casino Mitigation Grant funds from the Commonwealth of Massachusetts and local funding in the Capital Improvements section of the Town of Agawam's Fiscal Year 2026 Annual Operating Budget; and

WHEREAS, the temporary and permanent easements are shown on a plan entitled "Owned by the City of Agawam; Agawam, Massachusetts; Hampden County; Street Layout Plans; Showing Location of Easements for the Purpose of Reconstructing Cooper Street at Suffield Street for the City of Agawam" Dated March 11, 2026 which plan was prepared by: Christopher C. Danforth, PLS#41604 of VHB, 120 Front Street, Suite 500, Worcester, MA 01608 and includes takings on: Suffield Street, Cooper Street, and Rowley Street. Said plan shall be recorded in the Hampden County Registry of Deeds; and

WHEREAS, the temporary and permanent easements are further described in Exhibits 1 through 5 which are attached hereto and incorporated herein by reference; and

WHEREAS, it is in the best interests of the City of Agawam to complete the reconstruction of the intersection located at Cooper Street, Suffield Street and Rowley Street; and

NOW THEREFORE, the Agawam City Council under the authority vested in it by Massachusetts General Laws Chapter 79 and Chapter 40 §14 hereby resolves as follows:

- (a) That the City of Agawam adopt Orders of Taking by eminent domain pursuant to Massachusetts General Laws Chapter 79 and Chapter 40 §14 of the temporary and permanent easements described in Exhibits 1 through 5 which are attached hereto and incorporated herein by reference for the reconstruction of the intersection located at Cooper Street, Suffield Street and Rowley Street together with all structures affixed thereto and all trees thereon, as well as, with the benefit of all rights therein both legal and equitable, including but not limited to all estates, privileges and appurtenances, restrictions, conditions and all estates and rights of reverter related thereto. Betterments shall not be assessed for said Orders of Taking.
- (b) Said Orders of Taking shall be for the municipal purpose of completing the reconstruction of the intersection located at Cooper Street, Suffield Street and Rowley Street.
- (c) The present owners of the parcels described in Exhibits 1 through 5 shall be entitled to damages in accordance with Massachusetts General Laws Chapter 79 in the amounts reflected in said Exhibits 1 through 5. The right to damages shall vest upon recording the Orders of Taking.
- (d) The Treasurer is authorized to pay the sums listed in Exhibits 1 through 5 to the present owners of the parcels therein described or their heirs, executors, administrators, successors or assigns as the case may be. The Treasurer shall pay the above sum from the monies appropriated by the Agawam City Council for the purposed expressed herein.
- (e) The City Clerk is hereby authorized to certify said Orders of Taking and cause them to be recorded in the Hampden County Registry of Deeds within thirty (30) days after adoption in accordance with Massachusetts General Laws Chapter 79.
- (f) The City Clerk shall upon recording said Orders of Taking in the Hampden County Registry of Deeds, in the name and on behalf of the Agawam City Council, give notice to every person, including every mortgagee of record, whose property has been taken or who is otherwise entitled to damages on account of said takings. Said notice shall be given in accordance with Massachusetts General Laws Chapter 79. The City Clerk shall also give all other notices required under Chapter 79 of Massachusetts General Laws.

Dated this _____ day of _____, 2026.

PER ORDER OF THE AGAWAM CITY COUNCIL

 Anthony J. Russo, President

APPROVED AS TO FORM AND LEGALITY



 Christopher S. Cappucci, Solicitor

EXHIBIT 1

Property: 332 Suffield Street, Agawam, Massachusetts
Current Owner: Walz Realty, LLC
Deed Reference: Hampden County Registry of Deeds Book 18582, Page 234

Exhibit 1 pertains to an area on property located at 332 Suffield Street, Agawam, Hampden County, Massachusetts which is more particularly described in a deed which is recorded in the Hampden County Registry of Deeds at Book 18582, Page 234.

- a. It is the intention to take a **permanent easement** and a **temporary easement** on this property, designated as **Parcel E-1** and **Parcel TE-2**, which are shown on the plan entitled: "Owned by the City of Agawam; Agawam, Massachusetts; Hampden County; Street Layout Plans; Showing Location of Easements for the Purpose of Reconstructing Cooper Street at Suffield Street for the City of Agawam" Dated March 11, 2026 which plan was prepared by: Christopher C. Danforth, PLS#41604 of VHB, 120 Front Street, Suite 500, Worcester, MA 01608. The temporary easement shall be in effect for a period of no more than five (5) years from the date of the recording of the Order of Taking.
- b. The permanent and temporary easements are further described as follows:
 - i. Permanent Easement: Parcel E-1: A parcel of land shown as Parcel E-1 on the aforementioned plan which is bounded and described as follows: Beginning at the northerly corner of the parcel herein described in the easterly line of the CITY LAYOUT of Cooper Street. Said point can also be further described as being located S.41°01'21"E. a distance of 23.27 feet from station 52+59.04 on the Cooper Street construction baseline; running thence N.50°04'06"E. a distance of 23.74 feet to a point; thence turning and running S.7°36'26"W. a distance of 23.79 feet to a point; thence turning and running N.61°00'41"W. a distance of 17.21 feet to the point of beginning. Parcel E-1 contains 191 square feet of area, more or less.
 - ii. Temporary Easement: Parcel TE-2: A parcel of land shown as Parcel TE-2 on the aforementioned plan which is comprised of a strip of land which is three feet in width, more or less, along the south side of the Suffield, Cooper, Rowley Street intersection which extends along Parcel E-1 which is described above. Parcel TE-2 contains 55 square feet of area, more or less.
- c. The appraised value of Parcel E-1 and Parcel TE-2 is One Thousand Three Hundred Forty and 00/100 (\$1,340.00) Dollars.

EXHIBIT 2

Property: 402 Cooper Street, Agawam, Massachusetts
Current Owner: Alfred Pajer a/k/a Alfred J. Pajer, Life Tenant and
Alfred Pajer, Trustee, Theresa A. Heckman, Trustee and
Richard A. Walker, Trustee of the Alfred Pajer Trust
Deed Reference: Hampden County Registry of Deeds Book 19399, Page 342

Exhibit 2 pertains to an area on property located at 402 Cooper Street, Agawam, Hampden County, Massachusetts which is more particularly described in a deed which is recorded in the Hampden County Registry of Deeds at Book 19399, Page 342.

- a. It is the intention to take a **permanent easement** and a **temporary easement** on this property, designated as **Parcel E-2** and **Parcel TE-3**, which are shown on the plan entitled: "Owned by the City of Agawam; Agawam, Massachusetts; Hampden County; Street Layout Plans; Showing Location of Easements for the Purpose of Reconstructing Cooper Street at Suffield Street for the City of Agawam" Dated March 11, 2026 which plan was prepared by: Christopher C. Danforth, PLS#41604 of VHB, 120 Front Street, Suite 500, Worcester, MA 01608. The temporary easement shall be in effect for a period of no more than five (5) years from the date of the recording of the Order of Taking.
- b. The permanent and temporary easements are further described as follows:
 - i. Permanent Easement: Parcel E-2: A parcel of land shown as Parcel E-2 on the aforementioned plan which is bounded and described as follows: Beginning at the easterly corner of the parcel herein described in the westerly line of the CITY LAYOUT of Cooper Street. Said point can also be further described as being located N.41°01'21"W. a distance of 26.34 feet from station 52+75.07 on the Cooper Street construction baseline; running thence S.7°22'40"E. a distance of 17.81 feet to a point; thence turning and running S.53°58'54"E. a distance of 15.47 feet to a point along the easterly line of the CITY LAYOUT of Rowley Street; thence turning and running S.50°04'06"W. a distance of 13.34 feet along the westerly line of the CITY LAYOUT of Cooper Street to the point of beginning. Parcel E-2 contains 100 square feet of area, more or less.
 - ii. Temporary Easement: Parcel TE-3: A parcel of land shown as Parcel TE-3 on the aforementioned plan which is comprised of a strip of land which is three feet in width, more or less, along the west side of the Suffield, Cooper, Rowley Street intersection which extends along the frontage of 402 Cooper Street and along Parcel E-2 which is described above. Parcel TE-3 contains 468 square feet of area, more or less.
- c. The appraised value of Parcel E-2 and Parcel TE-3 is One Thousand Eight Hundred Eighty and 00/100 (\$1,880.00) Dollars.

EXHIBIT 3

Property: 373 Rowley Street, Agawam, Massachusetts
Current Owner: MAAHI Petroleum Corp.
Deed Reference: Hampden County Registry of Deeds Book 19112, Page 129

Exhibit 3 pertains to an area on property located at 373 Rowley Street, Agawam, Hampden County, Massachusetts which is more particularly described in a deed which is recorded in the Hampden County Registry of Deeds at Book 19112, Page 129.

- a. It is the intention to take a **permanent easement** and a **temporary easement** on this property, designated as **Parcel E-3** and **Parcel TE-4**, which are shown on the plan entitled "Owned by the City of Agawam; Agawam, Massachusetts; Hampden County; Street Layout Plans; Showing Location of Easements for the Purpose of Reconstructing Cooper Street at Suffield Street for the City of Agawam" Dated March 11, 2026 which plan was prepared by: Christopher C. Danforth, PLS#41604 of VHB, 120 Front Street, Suite 500, Worcester, MA 01608. The temporary easement shall be in effect for a period of no more than five (5) years from the date of the recording of the Order of Taking.
- b. The permanent and temporary easements are further described as follows:
 - i. Permanent Easement: Parcel E-3: A parcel of land shown as Parcel E-3 on the aforementioned plan which is bounded and described as follows: Beginning at the southerly corner of the parcel herein described in the westerly line of the CITY LAYOUT of Rowley Street. Said point can also be further described as being located N.36°03'11"E. a distance of 24.26 feet from station 22+03.38 on the Rowley Street construction baseline, and running thence N.67°35'32"E. a distance of 9.89 feet to a point; thence turning and running S.7°36'26"W. a distance of 9.58 feet to a point along the westerly line of the CITY LAYOUT of Suffield Street; thence turning and running N.53°58'54"W. a distance of 9.73 feet along the westerly line of the CITY LAYOUT of Rowley Street to the point of beginning. Parcel E-3 contains 41 square feet of area, more or less.
 - ii. Temporary Easement: Parcel TE-4: A parcel of land shown as Parcel TE-4 on the aforementioned plan which is comprised of a strip of land which is eight feet in width, more or less, along the north west side of the Suffield, Cooper, Rowley Street intersection which extends along Parcel E-3 which is described above. Parcel TE-4 contains 98 square feet of area, more or less.
- c. The appraised value of Parcel E-3 and Parcel TE-4 is Seven Hundred and 00/100 (\$700.00) Dollars.

EXHIBIT 4

Property: 305 Suffield Street, Agawam, Massachusetts
Current Owner: Mass Veterinary Services LLC
Deed Reference: Hampden County Registry of Deeds Book 25400, Page 81

Exhibit 4 pertains to an area on property located at 305 Suffield Street, Agawam, Hampden County, Massachusetts which is more particularly described in a deed which is recorded in the Hampden County Registry of Deeds at Book 25400, Page 81.

- a. It is the intention to take a **permanent easement** and a **temporary easement** on this property, designated as **Parcel E-4** and **Parcel TE-5**, which are shown on the plan entitled "Owned by the City of Agawam; Agawam, Massachusetts; Hampden County; Street Layout Plans; Showing Location of Easements for the Purpose of Reconstructing Cooper Street at Suffield Street for the City of Agawam" Dated March 11, 2026 which plan was prepared by: Christopher C. Danforth, PLS#41604 of VHB, 120 Front Street, Suite 500, Worcester, MA 01608. The temporary easement shall be in effect for a period of no more than five (5) years from the date of the recording of the Order of Taking.
- b. The permanent and temporary easements are further described as follows:
 - i. Permanent Easement: Parcel E-4: A parcel of land shown as Parcel E-4 on the aforementioned plan which is bounded and described as follows: Beginning at the southerly corner of the parcel herein described in the easterly line of the CITY LAYOUT of Suffield Street. Said point can also be further described as being located S.82°35'33"E. a distance of 25.04 feet from station 104+02.74 on the Suffield Street construction baseline, running thence N.7°36'26"E. a distance of 28.33 feet to a point along the easterly line of the CITY LAYOUT of Suffield Street; thence turning and running S.48°25'35"E. a distance of 15.86 feet to a point; thence turning and running S.41°40'00"W. a distance of 23.49 feet along the westerly line of the CITY LAYOUT of Cooper Street to the point of beginning. Parcel E-4 contains 186 square feet of area, more or less.
 - ii. Temporary Easement: Parcel TE-5: A parcel of land shown as Parcel TE-5 on the aforementioned plan which is comprised of a strip of land which is six feet in width, more or less, along the north east side of the Suffield, Cooper, Rowley Street intersection which extends along Parcel E-4 which is described above. Parcel TE-5 contains 280 square feet of area, more or less.
- c. The appraised value of Parcel E-4 and Parcel TE-5 is Two Thousand Two Hundred Eighty and 00/100 (\$2,280.00) Dollars.

EXHIBIT 5

Property: 319 Suffield Street, Agawam, Massachusetts
Current Owner: Alfred Pajer a/k/a Alfred J. Pajer, Life Tenant and
Alfred Pajer, Trustee, Theresa A. Heckman, Trustee and
Richard A. Walker, Trustee of the Alfred Pajer Trust
Deed Reference: Hampden County Registry of Deeds Book 19399, Page 342

Exhibit 5 pertains to an area on property located at 319 Suffield Street, Agawam, Hampden County, Massachusetts which is more particularly described in a deed which is recorded in the Hampden County Registry of Deeds at Book 19399, Page 342.

- a. It is the intention to take a **permanent easement** and a **temporary easement** on this property, designated as **Parcel E-5** and **Parcel TE-1**, which are shown on the plan entitled "Owned by the City of Agawam; Agawam, Massachusetts; Hampden County; Street Layout Plans; Showing Location of Easements for the Purpose of Reconstructing Cooper Street at Suffield Street for the City of Agawam" Dated March 11, 2026 which plan was prepared by: Christopher C. Danforth, PLS#41604 of VHB, 120 Front Street, Suite 500, Worcester, MA 01608. The temporary easement shall be in effect for a period of no more than five (5) years from the date of the recording of the Order of Taking.
- b. The permanent and temporary easements are further described as follows:
 - i. Permanent Easement: Parcel E-5: A parcel of land shown as Parcel E-5 on the aforementioned plan which is bounded and described as follows: Beginning at the westerly corner of the parcel herein described in the easterly line of the CITY LAYOUT of Suffield Street. Said point can also be further described as being located S.82°12'55"E. a distance of 25.19 feet from station 103+11.12 on the Suffield Street construction baseline, running thence N.7°36'36"E. a distance of 5.00 feet to a point along the easterly line of the CITY LAYOUT of Suffield Street; thence turning and running S.82°23'34"E. a distance of 3.00 feet to a point; thence turning and running S.7°36'26"W. a distance of 5.00 feet to a point; thence turning and running N.82°23'34"W. a distance of 3.00 feet to the point of beginning. Parcel E-5 contains 15 square feet of area, more or less.
 - ii. Temporary Easement: Parcel TE-1: A parcel of land shown as Parcel TE-1 on the aforementioned plan which is comprised of a strip of land which is four feet in width, more or less, along the east side of the Suffield, Cooper, Rowley Street intersection which extends along the frontage of 319 Suffield Street and Parcel E-5 which is described above. Parcel TE-1 contains 1,401 square feet of area, more or less.
- c. The appraised value of Parcel E-5 and Parcel TE-1 is Seven Hundred Twenty and 00/100 (\$720.00) Dollars.



Town of Agawam

Christopher C. Johnson, Mayor
36 Main Street
Agawam, MA 01001
Telephone: 413-786-0400 | 413-786-4520

Memorandum

To: Agawam City Council
From: Christopher C. Johnson, Mayor
Re: TR-2026-16 (Suffield/Cooper/Rowley Street Intersection)
Date: April 2, 2026

TR-2026-16 is a resolution authorizing an Order of Taking for the reconstruction of the Suffield, Cooper and Rowley Street intersection. The project will include the addition of a north bound turn lane on Suffield Street to allow for cars to turn west onto Cooper and Rowley Streets without blocking the northbound traffic on Suffield Street. It will also include the addition of actuated pedestrian crosswalks on all five roadways that lead into the intersection, and the replacement of the traffic lights and controls.

The DPW was awarded a \$100,000 grant for the preparation of a preliminary design of this intersection as part of the Massachusetts Casino Community Mitigation Fund. The DPW was subsequently awarded an \$833,000 construction grant from the same fund. The town received an estimate to complete the project of \$1,700,000 from our consulting engineers. The balance of the funding required to complete the project was appropriated in the Capital Improvement section of the FY2026 Annual Operating Budget.

The consulting engineers are presently completing final specifications and bid documents to complete the project. Construction is expected to begin in late spring or early summer this year with completion by early fall.

Please do not hesitate to contact me with any questions.

Very truly yours,

Christopher C. Johnson
Mayor

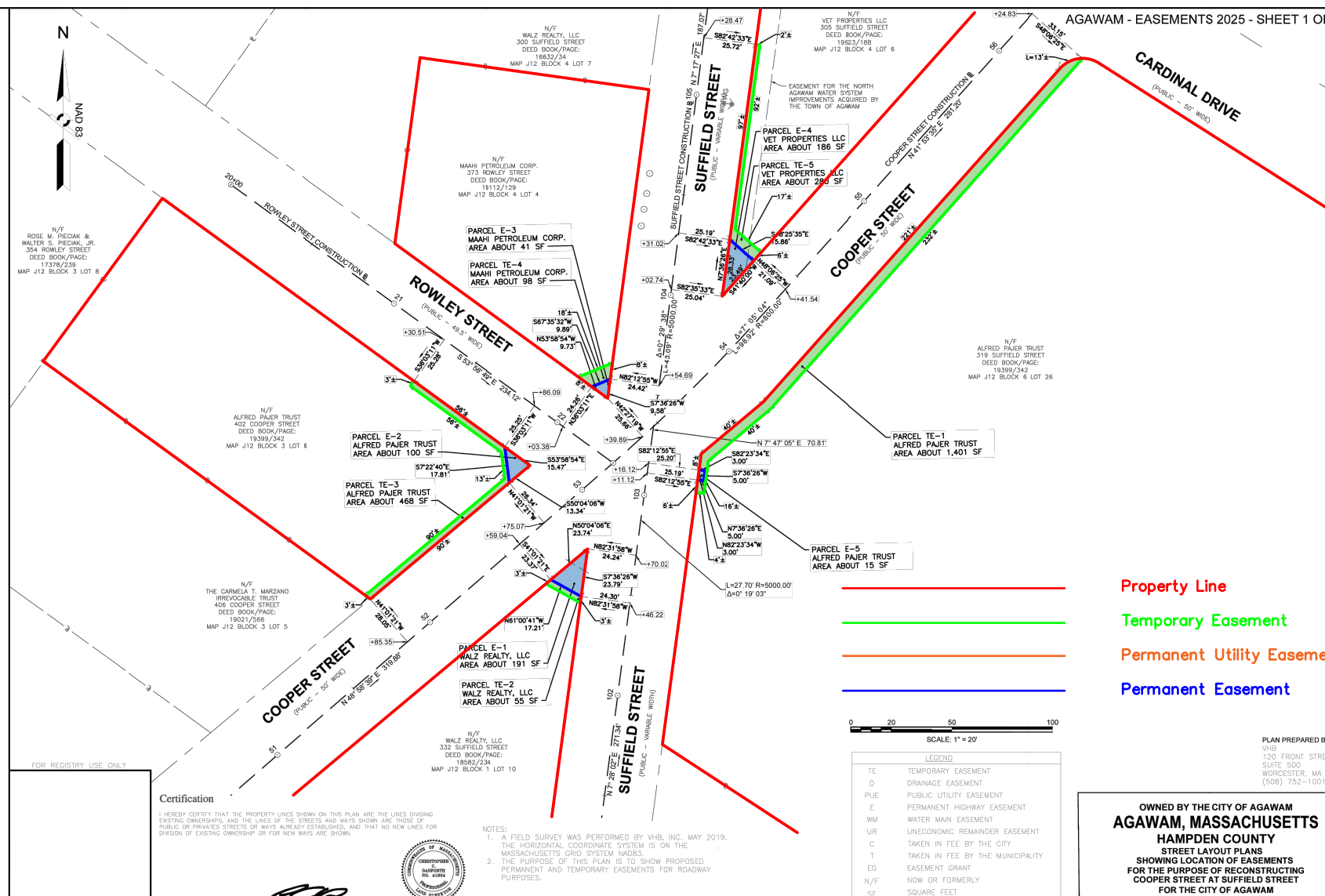

N/F
ROSE M. PIECIAK &
WALTER S. PIECIAK, JR.
304 ROWLEY STREET
DEED BOOK/PAGE:
17378/239
MAP J12 BLOCK 3 LOT 8

N/F
WALZ REALTY, LLC
300 SUFFIELD STREET
DEED BOOK/PAGE:
18632/24
MAP J12 BLOCK 4 LOT 7

N/F
MAHAI PETROLEUM CORP.
373 ROWLEY STREET
DEED BOOK/PAGE:
19112/129
MAP J12 BLOCK 4 LOT 4

N/F
VET PROPERTIES LLC
305 SUFFIELD STREET
DEED BOOK/PAGE:
19623/188
MAP J12 BLOCK 4 LOT 6

PARCEL E-4
VET PROPERTIES LLC
AREA ABOUT 186 SF

PARCEL TE-5
VET PROPERTIES LLC
AREA ABOUT 280 SF

PARCEL E-3
MAHAI PETROLEUM CORP.
AREA ABOUT 41 SF

PARCEL TE-4
MAHAI PETROLEUM CORP.
AREA ABOUT 98 SF

N/F
ALFRED PAJER TRUST
402 COOPER STREET
DEED BOOK/PAGE:
19399/342
MAP J12 BLOCK 3 LOT 6

PARCEL E-2
ALFRED PAJER TRUST
AREA ABOUT 100 SF

PARCEL TE-3
ALFRED PAJER TRUST
AREA ABOUT 468 SF

N/F
THE CARMELA T. MARZANO
IRREVOCABLE TRUST
406 COOPER STREET
DEED BOOK/PAGE:
19021/566
MAP J12 BLOCK 3 LOT 5

PARCEL E-1
WALZ REALTY, LLC
AREA ABOUT 191 SF

PARCEL TE-2
WALZ REALTY, LLC
AREA ABOUT 55 SF

N/F
WALZ REALTY, LLC
332 SUFFIELD STREET
DEED BOOK/PAGE:
18580/234
MAP J12 BLOCK 1 LOT 10

N/F
ALFRED PAJER TRUST
319 SUFFIELD STREET
DEED BOOK/PAGE:
19399/342
MAP J12 BLOCK 6 LOT 26

PARCEL TE-1
ALFRED PAJER TRUST
AREA ABOUT 1,401 SF

PARCEL E-5
ALFRED PAJER TRUST
AREA ABOUT 15 SF

- Property Line
- Temporary Easement
- Permanent Utility Easement
- Permanent Easement

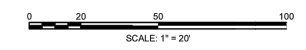

LEGEND	
TE	TEMPORARY EASEMENT
D	DRAINAGE EASEMENT
PUE	PUBLIC UTILITY EASEMENT
E	PERMANENT HIGHWAY EASEMENT
WM	WATER MAIN EASEMENT
UR	UNECONOMIC REMAINDER EASEMENT
C	TAKEN IN FEE BY THE CITY
T	TAKEN IN FEE BY THE MUNICIPALITY
EG	EASEMENT GRANT
N/F	NOW OR FORMERLY
SF	SQUARE FEET

PLAN PREPARED BY:
VINCE
120 FRONT STREET
SUITE 500
WORCESTER, MA 01608
(508) 752-1001

**OWNED BY THE CITY OF AGAWAM
AGAWAM, MASSACHUSETTS
HAMPDEN COUNTY**
STREET LAYOUT PLANS
SHOWING LOCATION OF EASEMENTS
FOR THE PURPOSE OF RECONSTRUCTING
COOPER STREET AT SUFFIELD STREET
FOR THE CITY OF AGAWAM

Certification
I HEREBY CERTIFY THAT THE PROPERTY LINES SHOWN ON THIS PLAN ARE THE LINES DIVIDING EXISTING OWNERSHIPS, AND THE LINES OF THE STREETS AND WAYS SHOWN ARE THOSE OF PUBLIC OR PRIVATE STREETS OR WAYS ALREADY ESTABLISHED, AND THAT NO NEW LINES FOR DIVISION OF EXISTING OWNERSHIP OR FOR NEW WAYS ARE SHOWN.

- NOTES:
1. A FIELD SURVEY WAS PERFORMED BY VHB, INC., MAY 2019. THE HORIZONTAL COORDINATE SYSTEM IS ON THE MASSACHUSETTS GRID SYSTEM NAD83.
 2. THE PURPOSE OF THIS PLAN IS TO SHOW PROPOSED PERMANENT AND TEMPORARY EASEMENTS FOR ROADWAY PURPOSES.



03-11-2028
CHRISTOPHER L. DANFORTH, PLS #41804

TR-2026-17

A RESOLUTION TO APPROPRIATE AND AUTHORIZE BORROWING IN THE AMOUNT OF TWO MILLION FIVE HUNDRED SEVENTY-SEVEN THOUSAND THREE HUNDRED NINETY-EIGHT (\$2,577,398.00) DOLLARS FOR THE PURCHASE OF TWO FIRE ENGINE PUMP TRUCKS FOR THE AGAWAM FIRE DEPARTMENT

(Sponsored by Christopher C. Johnson, Mayor)

WHEREAS, the Agawam Fire Department currently has four fire engine pump trucks with two assigned to each station; and

WHEREAS, two of the current fire engine pump trucks were purchased in 2018 and they are currently deployed as the front line vehicles in each station, and the other two fire engine pump trucks were purchased in 2008 and they are deployed as reserve vehicles in each station; and

WHEREAS, the 2008 fire engine pump trucks are nearing the end of their serviceable life and there is a considerable lead time (estimated at 850 days) to have new vehicles manufactured and delivered; and

WHEREAS, the Fire Department has received a quote for the manufacture of two new fire engine pump trucks of One Million Two Hundred Eighty-Eight Thousand Six Hundred Ninety-Nine (\$1,288,699.00) Dollars per truck for a total amount of Two Million Five Hundred Seventy-Seven Thousand Three Hundred Ninety-Eight (\$2,577,398.00) Dollars, which includes a trade in allowance of Forty-Five Thousand (\$45,000.00) Dollars for each of our 2008 trucks; and

WHEREAS, the current build time for these new fire engine pump trucks is estimated at 850 days which would result in their delivery to the Agawam Fire Department in late 2028; and

WHEREAS, it is in the best interests of the Town of Agawam to appropriate and authorize borrowing in the amount of Two Million Five Hundred Seventy-Seven Thousand Three Hundred Ninety-Eight (\$2,577,398.00) Dollars to purchase two new fire engine pump trucks for the Agawam Fire Department; and

NOW THEREFORE, the Agawam City Council hereby resolves to authorize the following:

1. That the City known as the Town of Agawam appropriates the amount of Two Million Five Hundred Seventy-Seven Thousand Three Hundred Ninety-Eight (\$2,577,398.00) Dollars for the purpose of funding the cost to purchase two fire engine pump trucks for the Agawam Fire Department (the Project).

2. To meet this appropriation, the Treasurer, with the approval of the Mayor, is authorized to borrow Two Million Five Hundred Seventy-Seven Thousand Three Hundred Ninety-Eight (\$2,577,398.00) Dollars to pay the costs of this Project, including the payment of all costs incidental and related thereto under Massachusetts General Laws Chapter 44 or any other enabling authority; and to issue bonds or notes of the City known as the Town of Agawam therefore, and the Mayor is authorized to take any other action necessary to carry out this Project.

DATED THIS ____ DAY OF _____, 2026.

PER ORDER OF THE AGAWAM CITY COUNCIL

Anthony J. Russo, President

APPROVED AS TO FORM AND LEGALITY



Christopher S. Cappucci, Solicitor

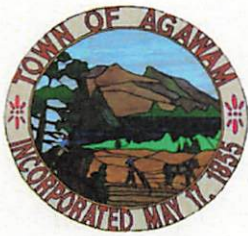

Town of Agawam

Christopher C. Johnson, Mayor
36 Main Street
Agawam, MA 01001
Telephone: 413-786-0400 | 413-786-4520

Memorandum

To: Agawam City Council
From: Christopher C. Johnson, Mayor
Re: TR-2026-17 (2 new Fire Engine Pump Trucks)
Date: April 2, 2026

TR-2026-17 is a resolution authorizing the appropriation and borrowing to purchase two new fire engine pump trucks for the Agawam Fire Department. The Agawam Fire Department currently has four fire engine pump trucks with two assigned to each station. Two of the current fire engine pump trucks were purchased in 2018 and they are currently deployed as the front line vehicles in each station, and the other two fire engine pump trucks were purchased in 2008 and they are deployed as reserve vehicles in each station. The 2008 fire engine pump trucks are nearing the end of their serviceable life and there is a considerable lead time (estimated at 850 days) to have new vehicles manufactured and delivered.

The Fire Department has received a quote for the manufacture of two new fire engine pump trucks of One Million Two Hundred Eighty-Eight Thousand Six Hundred Ninety-Nine (\$1,288,699.00) Dollars per truck for a total amount of Two Million Five Hundred Seventy-Seven Thousand Three Hundred Ninety-Eight (\$2,577,398.00) Dollars, which includes a trade in allowance of Forty-Five Thousand (\$45,000.00) Dollars for each of our 2008 trucks. The current build time for these new fire engine pump trucks is estimated at 850 days which would result in their delivery to the Agawam Fire Department in late 2028.

You will note in the quote that the vendor is offering a discount of \$124,160 per truck if the bill is paid in advance at the time the order is placed. While this seems like favorable option, simple analysis proves otherwise. The Town currently earns 4% + on its reserve funds. If you take the discounted price for both vehicles (\$2,329,078.00) and invest it at 4% with compounding interest until the expected delivery date, the amount is almost the same as the discounted price. When you further consider that the last truck that the town purchased was delivered approximately 6 months after its expected completion date, it does not make sense to pay for the trucks in advance.

Please do not hesitate to contact me with any questions.

Very truly yours,

Christopher C. Johnson
Mayor



Agawam Fire Department

800 Main Street, Agawam, Massachusetts, 01001
Voice (413) 786-0657 ▪ www.agawam.ma.us/fire ▪ Fax (413) 786-1241



ALAN SIROIS, CHIEF OF DEPARTMENT
FRANK MATUSZCZAK, DEPUTY FIRE CHIEF
DEREK MYERS, FIRE INSPECTOR
DAN LIZOTTE, DRILL INSTRUCTOR
JOHN SAULENAS, EMS DIRECTOR

afdchief@agawam.ma.us
afddeputy@agawam.ma.us
afdinsp@agawam.ma.us
afdtraining@agawam.ma.us
afdems@agawam.ma.us

To: Agawam City Council
From: Fire Chief Alan Sirois
Re: Support for TR-2026-17 – Acquisition of Two Fire Engines
Date: March 25, 2026

This memorandum is submitted in strong support of TR-2026-17, which authorizes the appropriation and borrowing of \$2,577,398 for the purchase of two fire engines for the Agawam Fire Department.

The Agawam Fire Department currently operates a four-engine deployment model, with two engines assigned to each station. Two of these engines, purchased in 2018, serve as front-line apparatus and remain in good operational condition. The remaining two engines, purchased in 2008, are assigned as reserve units but are now approaching the end of their reliable service life. As these vehicles age, they are experiencing increased maintenance demands, higher repair costs, and a greater likelihood of mechanical failure during emergency response. While still functional, they no longer provide the level of reliability expected of reserve apparatus and instead present a growing operational vulnerability.

Delaying the replacement of these vehicles introduces clear and measurable risk to the community and the Department's ability to respond effectively. Aging apparatus are more prone to breakdowns, which can result in units being placed out of service more frequently. This reduces system reliability and limits operational redundancy across the two stations. In the event of a significant mechanical failure, a station could temporarily lose adequate fire suppression capability, increasing reliance on mutual aid from neighboring communities and potentially extending response times. These impacts directly affect both life safety and property conservation and are consistent with known trends in apparatus lifecycle performance.

The current estimated build time for new fire engine pump trucks is approximately 850 days, or more than two years from the time of order to delivery. Based on this timeline, approval of this project now would result in delivery in late 2028. Any delay in approval will push delivery further into the future, potentially extending into 2029 or beyond. Given the current condition of the reserve apparatus, postponing this decision will widen the gap between the end of reliable service life and the arrival of replacement units.

The total project cost for two new fire engine pump trucks is \$2,577,398, which includes a trade-in allowance of \$45,000 per unit for the existing 2008 apparatus. Although the vendor has offered a discount for full prepayment at the time of order, financial analysis indicates that this option does not provide a meaningful advantage. The Town's ability to earn approximately 4%

on existing invested funds results in a comparable return over the anticipated build period. Additionally, prepayment introduces unnecessary risk, particularly given prior experience with delivery delays beyond projected timelines. For these reasons, standard payment upon delivery remains the most fiscally responsible approach.

It is also important to recognize that delaying this purchase will almost certainly result in increased costs. Fire apparatus pricing has continued to rise due to inflationary pressures affecting raw materials, labor, and supply chains. Industry trends over the past several years have shown consistent year-over-year price increases, and there is no indication that this trend will reverse in the near term. Deferring this order exposes the Town to higher future procurement costs for the same equipment, reducing overall purchasing power and increasing long-term capital expenditures.

Approving this project will ensure that the Department maintains a reliable and modern fleet capable of supporting both front-line and reserve operations for the next 20 years. Replacing aging apparatus will reduce maintenance costs, minimize downtime, and improve overall system reliability. New apparatus will also incorporate current safety and performance standards, enhancing firefighter safety and operational effectiveness during emergency incidents. Furthermore, securing this purchase now protects the Town from continued cost escalation, supply chain uncertainty, and diminished purchasing power in future years.

This project represents a time-sensitive capital investment necessary to maintain the operational readiness of the Agawam Fire Department. The existing reserve engines are nearing the end of their service life, and the extended manufacturing timeline requires proactive action to avoid a future capability gap. For these reasons, it is recommended that the City Council approve TR-2026-17 as presented. This action will ensure continued delivery of reliable emergency services, protect public safety, and position the Town to manage long-term capital needs in a responsible and strategic manner.

Respectfully,



Alan Sirois, Fire Chief





NEW ENGLAND FIRE EQUIPMENT & APPARATUS CORPORATION

10 STILLMAN ROAD
NORTH HAVEN, CONNECTICUT 06473

TEL 203-234-5678

Chief Alan Sirois
Agawam Fire Department
800 Main Street
Agawam, MA 01001

March 6, 2026

Re: Revised Pumper Quote

Chief,

On February 20, 2026, you requested an extension of the price protection on this quote for an additional 60 days. As discussed, I was able to get an extension through our RSM Tim Burhart for 30 days with a plan to go for an additional 15-20 days at the time of expiration. During this conversation, you additionally asked for a little better on the trade-in allowance.

After discussions with my powers-that-be - and a thorough review of this job, I am pleased to provide you with this revised quote. Each pumper will now cost one million one hundred sixty-four thousand five hundred thirty-nine dollars (\$1,164,539.00). This price includes Sourcewell pricing via contract 082025-RVG-4 that matures on 12-08-2029 and with your Sourcewell membership number 100498. This price also includes a credit of \$124,160.00 for paying the full invoice at the time of contract signing. Additionally, a trade-in allowance of \$45,000 per apparatus for your current Engine 3 and Engine 4 is included. This quote also includes a performance bond for your protection as well as the usual factory travel for 4 trips (pre-con, chassis, mid-point and final inspections).

This quote is now valid through March 30, 2026 (Tim rounded it to the end of the month, so 40 days from the request/approval). At that time, I can likely get another 15-20 days. Current build time is 850 days from full contract execution.

As always, if you have any further questions, please let me know.

Thanks,
Dave

David J Farrell

David J Farrell
Sales Specialist
NEFEA
508-951-9399 cell
dfarrell@nefea.com

12' 0"
11' 0"
10' 0"
9' 0"
8' 0"
7' 0"
6' 0"
5' 0"
4' 0"
3' 0"
2' 0"
1' 0"

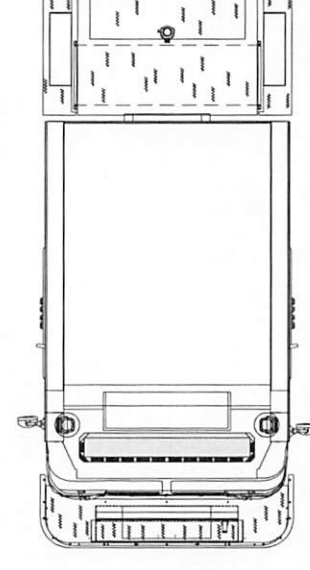
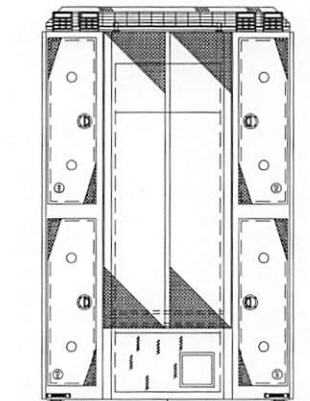
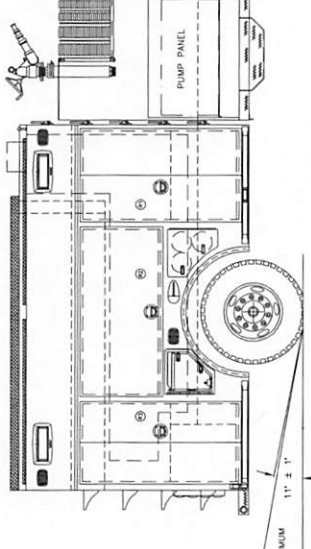
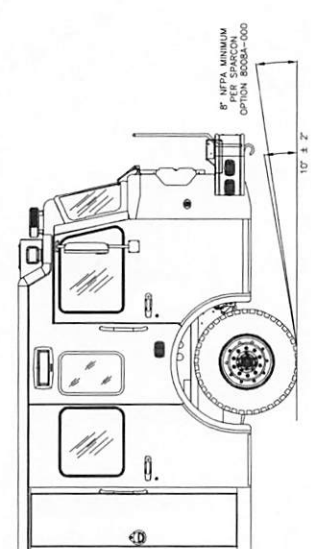
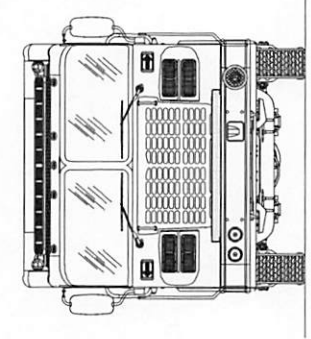

COMPARISON OF DIMENSIONS

COMPONENT	EXISTING	PROPOSED
WIDTH (CLEARANCE)	77" [6']	77" [6']
HEIGHT	122" [10'-2"]	122" [10'-2"]
LENGTH	390" [32'-6"]	390" [32'-6"]
WHEELBASE	114" [9'-6"]	114" [9'-6"]
TRACK	54" [4'-6"]	54" [4'-6"]
STEEPENING HEIGHT	100"	100"
WHEEL RADIUS	18" [1'-6"]	18" [1'-6"]
GROUND CLEARANCE	10"	10"
MINIMUM CLEARANCE	10"	10"
MAXIMUM CLEARANCE	10"	10"
MINIMUM TURNING RADIUS	10"	10"
MAXIMUM TURNING RADIUS	10"	10"

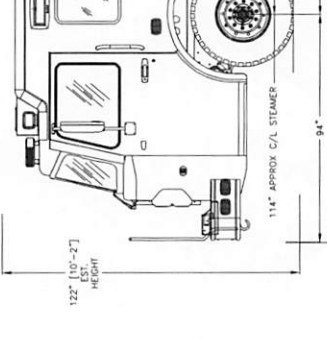
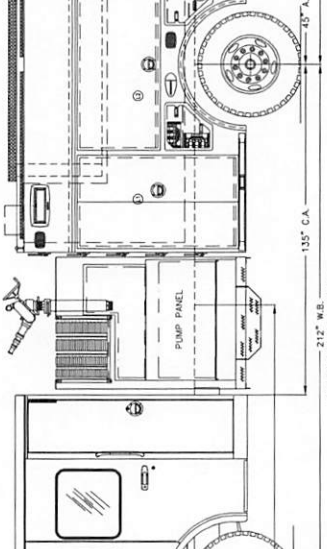
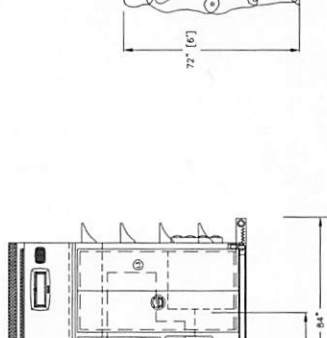
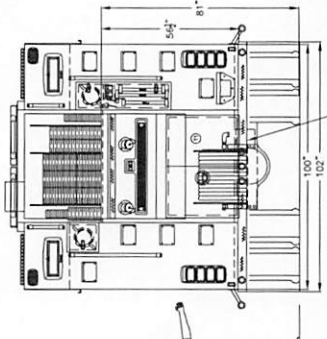

AGAWAM FIRE DEPARTMENT
AGAWAM FIRE
SIC: 8000
NAFTA
1/27" x 1" DWG NO. D.BROOD | Rev 01/23/2025
SIZE: 24" X 36"
SHEET: 1 OF 1

ENGINE: SAMPSON ELIEN 110' RATED PUMP
ENGINE: CUMMINS X15 450HP WITH ALLISON 3000 LOS W/ACTRIDER
TANK: 750 GALS. CAP.
WATER TANK: N/A
FOAM CELL: ALUMINUM
PUMP: 100 GPM @ 150 PSI
COMPARTMENTS: 250 CUBIC FEET

PROPOSAL

REVISION RECORD

NO.	DATE	BY	DESCRIPTION
01	01/23/25	[Signature]	INITIAL LAYOUT
02	01/23/25	[Signature]	150 GPM AND W/COMPS FOR 2027 EMISSIONS
03	01/16/25	[Signature]	150 GPM AND W/COMPS FOR 2027 EMISSIONS
04	01/16/25	[Signature]	150 GPM AND W/COMPS FOR 2027 EMISSIONS

NOTE: THIS DRAWING IS THE PROPERTY OF SAMPSON FIRE LLC AND IS TO BE USED ONLY IN REFERENCE TO THE WORK PERFORMED BY SAMPSON FIRE LLC AND NOT BE REPRODUCED IN ANY MANNER WITHOUT THE WRITTEN PERMISSION OF SAMPSON FIRE LLC. SAMPSON FIRE LLC IS NOT RESPONSIBLE FOR ANY ERRORS OR OMISSIONS. SAMPSON FIRE LLC IS NOT RESPONSIBLE FOR ANY DAMAGE TO PROPERTY OR PERSONS. SAMPSON FIRE LLC IS NOT RESPONSIBLE FOR ANY DAMAGE TO PROPERTY OR PERSONS. SAMPSON FIRE LLC IS NOT RESPONSIBLE FOR ANY DAMAGE TO PROPERTY OR PERSONS.

TR-2026-18

**A RESOLUTION CONFIRMING THE REAPPOINTMENT OF
HENRY A. KOZLOSKI, 102 MEADOW STREET, AGAWAM, MA.
TO THE COMMUNITY PRESERVATION ACT COMMITTEE TO A TERM
EXPIRING APRIL 30, 2029**

(Sponsored by Christopher C. Johnson, Mayor)

WHEREAS, the appointment of Henry A. Kozloski as representative of the Agawam Conservation Commission on the Agawam Community Preservation Act Committee will expire on April 30, 2026; and

WHEREAS, Henry A. Kozloski, 102 Meadow Street, Agawam, MA wishes to be reappointed; and

WHEREAS, at their March 26, 2026 meeting, the Agawam Conservation Commission voted on and confirmed that Henry A. Kozloski be reappointed as their representative on the Community Preservation Act Committee; and

NOW, THEREFORE, THE AGAWAM CITY COUNCIL hereby resolves to confirm the reappointment of Henry A. Kozloski, 102 Meadow Street, Agawam, MA, to the Agawam Community Preservation Act Committee for a term expiring April 30, 2029.

Dated this _____ day of _____, 2026

PER ORDER OF THE AGAWAM CITY COUNCIL

Anthony J. Russo, Council President

APPROVED AS TO FORM AND LEGALITY



Christopher S. Cappucci, City Solicitor



Town of Agawam Conservation Commission

1000 Suffield Street
Agawam, MA 01001
Telephone:
413-786-0400 ext. 8245
Fax: 413-786-9927

March 27, 2026

Mayor Christopher Johnson
36 Main Street
Agawam, Ma 01001

Dear Mayor Johnson:

At its duly called meeting held on March 26, 2026, the Agawam Conservation Commission voted to appoint Henry Kozloski as the Conservation Commission representative to the CPA Committee.

If you have any questions, please contact this office.

Sincerely,

Henry A. Kozloski, chair
Agawam Conservation Commission

Cc: Town Clerk, File, CPA

TR-2026-19

**A RESOLUTION CONFIRMING THE REAPPOINTMENT OF FRANK DeSTEFANO,
918 SHOEMAKER LANE, FEEDING HILLS, MA. TO THE COMMUNITY
PRESERVATION ACT COMMITTEE TO A TERM EXPIRING APRIL 30, 2029**

(Sponsored by Christopher C. Johnson, Mayor)

WHEREAS, the appointment of Frank DeStefano on the Agawam Community Preservation Act Committee expires on April 30, 2026; and

WHEREAS, Frank DeStefano, 918 Shoemaker Lane, Feeding Hills, MA wishes to be reappointed; and

WHEREAS, the reappointment of Frank DeStefano was voted on and confirmed by the Agawam Planning Board at their April 2, 2026 meeting; and

NOW, THEREFORE, THE AGAWAM CITY COUNCIL hereby resolves to confirm the appointment of Frank Destefano, 918 Shoemaker Lane, Feeding Hills, MA, to the Agawam Community Preservation Act Committee for a term expiring April 30, 2029.

Dated this _____ day of _____, 2026

PER ORDER OF THE AGAWAM CITY COUNCIL

Anthony J. Russo, Council President

APPROVED AS TO FORM AND LEGALITY



Christopher S. Cappucci, City Solicitor



Town of Agawam Planning Board

1000 Suffield Street
Agawam, MA 01001
Telephone:
413-786-0400 ext. 8245
Fax: 413-786-9927

March 20, 2026

Mayor Christopher Johnson
36 Main Street
Agawam, Ma 01001

Dear Mayor Johnson:

At its duly called meeting held on April 2, 2026, the Agawam Planning Board voted to appoint Frank DeStefano as the planning board representative to the CPA Committee.

If you have any questions, please contact this office.

Sincerely,

Frank DeStefano, Vice Chairman
Agawam Planning Board

Cc: Town Clerk, File, CPA

TR-2026-21

**A RESOLUTION ACCEPTING A GRANT FROM THE
EXECUTIVE OFFICE OF PUBLIC SAFETY AND SECURITY
AND THE DEPARTMENT OF FIRE SERVICES IN THE AMOUNT OF
EIGHTEEN THOUSAND SEVEN HUNDRED SIXTY
(\$18,760.00) DOLLARS TO THE AGAWAM FIRE DEPARTMENT
PURSUANT TO MASSACHUSETTS GENERAL LAWS
CHAPTER 44, SECTION 53(a)**

(Sponsored by Christopher C. Johnson, Mayor)

WHEREAS, the Department of Fire Services (DFS), a division within the Commonwealth of Massachusetts Executive Office of Public Safety and Security has awarded the Town of Agawam Fire Department a Firefighter Safety Equipment Grant in the amount of Eighteen Thousand Seven Hundred Sixty (\$18,760.00) Dollars; and

WHEREAS, the Agawam Fire Department will use the grant funds to purchase four sets of structural firefighting personal protective equipment, four sets of coats and pants; and

WHEREAS, it is in the best interests of the Town of Agawam to accept said grant from the Commonwealth of Massachusetts Executive Office of Public Safety and Security Department of Fire Services (DFS); and

NOW THEREFORE, the Agawam City Council hereby resolves pursuant to Massachusetts General Laws Chapter 44, Section 53(a) to accept a Firefighter Safety Equipment Grant from the Commonwealth of Massachusetts Executive Office of Public Safety and Security Department of Fire Services (DFS) in the amount of Eighteen Thousand Seven Hundred Sixty (\$18,760.00) Dollars to the Agawam Fire Department.

Dated this _____ day of _____, 2026.

PER ORDER OF THE AGAWAM CITY COUNCIL

Anthony J. Russo, President

APPROVED AS TO FORM AND LEGALITY



Christopher S. Cappucci, Solicitor



OFFICE OF THE GOVERNOR
COMMONWEALTH OF MASSACHUSETTS
STATE HOUSE BOSTON, MA 02133
(617) 725-4000

MAURA T. HEALEY
GOVERNOR

KIMBERLEY DRISCOLL
LIEUTENANT GOVERNOR

March 31, 2026

Chief Alan Sirois
Town of Agawam
800 Main Street
Agawam, MA 01001

Dear Chief Sirois,

Congratulations! I am pleased to inform you that the Executive Office of Public Safety and Security and the Department of Fire Services (DFS) has awarded the Town of Agawam Fire Department \$18,760.00 of funding for the Firefighter Safety Equipment Grant Program in State Fiscal Year 2026.

With each new challenge, the fire service in Massachusetts demonstrates its ability to adapt, overcome, and continue providing the excellent level of services that the citizens of the Commonwealth have come to expect. Please know how thankful I am for this, and how grateful I am to be able to provide your department with this important equipment.

The contract, terms and conditions, and other documents for this program will be provided to you by DFS. Please contact Tim Moore at DFS with any questions about this award at 978-567-3721 or Timothy.Moore@mass.gov for contract terms, conditions, and other award documents.
Sincerely,

A handwritten signature in blue ink that reads "M. T. Healey".

GOVERNOR MAURA T. HEALEY

A handwritten signature in blue ink that reads "Kim Driscoll".

LT. GOVERNOR KIMBERLEY DRISCOLL

CC: Deputy Chief Frank Matuszczak

**A RESOLUTION APPROPRIATING AND AUTHORIZING
THE EXPENDITURE OF COMMUNITY PRESERVATION FUNDS FOR
FIELD IRRIGATION AT THE AGAWAM JUNIOR HIGH SCHOOL**

(Sponsored by the Community Preservation Act Committee)

WHEREAS, voters of Agawam accepted the provisions of the Community Preservation Act and chose to form a Community Preservation Committee (CPA); and

WHEREAS, Massachusetts General Laws, Chapter 44B, Section 5(b)(2) allows the Community Preservation Committee to make recommendations to the City Council which is the legislative body for Agawam; and

WHEREAS, Massachusetts General Laws, Chapter 44B, Section 5(d) states that the City Council as legislative body shall then take such action and approve such appropriations as recommended by the Community Preservation Committee; and

WHEREAS, CPA funds may be spent on the rehabilitation or restoration of any recreational land and may be spent on any open space that has been acquired or created using CPA funds; and

WHEREAS, the proposed CPA expenditure will allow for the installation of a new irrigation system on the field at the Agawam Junior High School; and

WHEREAS, the CPA Committee has recommended that the Agawam City Council appropriate and expend the amount of Forty One Thousand Eight Hundred Thirty Eight (\$41,838.00) Dollars from the CPA Unreserved Fund Balance; and

WHEREAS, it is in the best interests of the City of Agawam to appropriate from the community preservation fund and authorize the proposed CPA expenditure for the installation of an irrigation system at the field at the Agawam Junior High School; and

NOW THEREFORE, the Agawam City Council hereby resolves, appropriates and authorizes the expenditure of Community Preservation Funds in the amount of Forty One Thousand Eight Hundred Thirty Eight (\$41,838.00) Dollars from the CPA Unreserved Fund Balance for the installation of an irrigation system at the field at the Agawam Junior High School in accordance with Massachusetts General Laws, Chapter 44B, Section 6.

The Agawam City Council hereby further resolves that the Mayor is authorized to expend said funds, as permitted by law, and to do all things necessary for the purposes so stated.

Dated this _____ day of _____, 2026.

PER ORDER OF THE AGAWAM CITY COUNCIL

Anthony J. Russo, President

APPROVED AS TO FORM AND LEGALITY



Christopher Cappucci, Solicitor

APPROVED AS TO APPROPRIATION



Cheryl St. John, Auditor

**A RESOLUTION APPROPRIATING AND AUTHORIZING THE EXPENDITURE OF
COMMUNITY PRESERVATION FUNDS FOR REMOVAL OF BITTERSWEET AND
HABITAT RESTORATION**

(Sponsored by the Community Preservation Act Committee)

WHEREAS, voters of Agawam accepted the provisions of the Community Preservation Act and chose to form a Community Preservation Committee (CPA); and

WHEREAS, Massachusetts General Laws, Chapter 44B, Section 5(b)(2) allows the Community Preservation Committee to make recommendations to the City Council which is the legislative body for Agawam; and

WHEREAS, Massachusetts General Laws, Chapter 44B, Section 5(d) states that the City Council as legislative body shall then take such action and approve such appropriations as recommended by the Community Preservation Committee; and

WHEREAS, CPA funds may be spent on the rehabilitation or restoration of any recreational land and may be spent on any open space that has been acquired or created using CPA funds; and

WHEREAS, the proposed CPA expenditure will allow for bittersweet removal and habitat restoration at School Street Park and Agawam Riverwalk; and

WHEREAS, the CPA Committee has recommended that the Agawam City Council appropriate and expend the amount of Twenty Nine Thousand (\$29,000.00) Dollars from the CPA Unreserved Fund Balance; and

WHEREAS, it is in the best interests of the City of Agawam to appropriate from the community preservation fund and authorize the proposed CPA expenditure for the bittersweet removal and habitat restoration at School Street Park and Agawam Riverwalk; and

NOW THEREFORE, the Agawam City Council hereby resolves, appropriates and authorizes the expenditure of Community Preservation Funds in the amount of Forty One Thousand Eight Hundred Thirty Eight (\$41,838.00) Dollars from the CPA Unreserved Fund Balance for the bittersweet removal and habitat restoration at School Street Park and Agawam Riverwalk in accordance with Massachusetts General Laws, Chapter 44B, Section 6.

The Agawam City Council hereby further resolves that the Mayor is authorized to expend said funds, as permitted by law, and to do all things necessary for the purposes so stated.

Dated this ____ day of _____, 2026.

PER ORDER OF THE AGAWAM CITY COUNCIL

Anthony J. Russo, President

APPROVED AS TO FORM AND LEGALITY



Christopher Cappucci, Solicitor

APPROVED AS TO APPROPRIATION



Cheryl St. John, Auditor

A RESOLUTION AUTHORIZING THE RESERVATION AND APPROPRIATION OF FUNDS FROM THE COMMUNITY PRESERVATION FUND

WHEREAS, the voters of Agawam chose to form a Community Preservation Committee, and

WHEREAS, one of the Community Preservation Committee's requirements is that it reserves funds for specific uses under the Community Preservation Act; and

WHEREAS, the Community Preservation Committee has recommended that \$76,123.80 should be reserved for Open Space from the Community Preservation Fund estimated annual fund revenue for Fiscal Year 2027; and

WHEREAS, the Community Preservation Committee's has recommended that \$76,123.80 should be reserved for Historic Resources from the Community Preservation Fund estimated annual fund revenue for Fiscal Year 2027; and

WHEREAS, the Community Preservation Committee's has recommended that \$76,123.80 should be reserved for Community Housing from the Community Preservation Fund estimated annual fund revenue for Fiscal Year 2027; and

WHEREAS, the Community Preservation Committee's has recommended that \$38,061.90 should be reserved for Administrative Expenses from the Community Preservation Fund estimated annual fund revenue for Fiscal Year 2027; and

WHEREAS, the Community Preservation Committee's has recommended that \$494,804.69 should be reserved for Budgeted Reserve from the Community Preservation Fund estimated annual fund revenue for Fiscal Year 2027; and

NOW THEREFORE, BE IT RESOLVED BY THE AGAWAM CITY COUNCIL that funds from the Community Preservation Fund estimated annual fund revenue for Fiscal Year 2027 shall be reserved as follows:

\$76,123.80 reserved for Open Space;

\$76,123.80 reserved for Historic Resources;

\$76,123.80 reserved for Community Housing;

\$38,061.90 reserved for Administrative Expenses

\$494,804.69 reserved for Budgeted Reserve

Dated this _____ day of _____, 2026

PER ORDER OF THE AGAWAM CITY COUNCIL

Anthony J. Russo, President

APPROVED AS TO FORM AND LEGALITY



Christopher S. Cappucci, Solicitor

CERTIFIED AS TO FUNDS AVAILABILITY



Cheryl St. John, Auditor



TOWN OF AGAWAM
36 MAIN STREET
AGAWAM, MA 01001
Community Preservation Committee

Date: April 2, 2026
To: City Council
From: Jennifer Bonfiglio, CPA Administrator
RE: TR2026-24

Attached is a resolution for the reservation and appropriation of CPA funds from the FY27 estimated revenues.

In a city or town that accepts CPA, a community preservation surcharge is assessed on the municipality's real estate taxes. The surcharge is calculated by multiplying the real estate taxes on a parcel, as reduced by any property tax exemptions and abatement, by the adopted percentage of 1%. The Department of Revenue issues an estimated state match which is then added to the surcharge resulting in *total estimated annual revenues*. This year that match is estimated at 15%. In the event the match is higher, we will return to the Council for the additional appropriation of surplus funds as we have in the past.

The CPA committee and legislative body must reserve for future appropriation at least 10% of these estimated annual revenues for Historic Resources, Open Space and Community Housing. Of the remaining funds, up to 5% may be reserved for administrative expenses, while the balance remains undesignated and is also reserved for future use.

Below is the calculation used:

CPA	<u>FY2027 Estimated Revenue Calculations</u>
\$66,619,029.96	FY2027 Estimated Tax Levy
\$70,249.59	Abatements (historical average)
\$354,173.52	Exemptions (as submitted to DOR)
\$66,194,606.85	FY2027 Net Tax Levy
\$661,946.07	FY2027 estimated revenues (1% surcharge)
\$99,291.91	15% FY2027 State Match (DOR Estimate)
\$761,237.98	TOTAL FY2027 estimated revenues including state match
\$76,123.80	Reserve 10% for Affordable housing
\$76,123.80	Reserve 10% for Open Space
\$76,123.80	Reserve 10% for Historic Preservation
\$38,061.90	Reserve 5% for Administrative expenses
\$494,804.69	Reserve 65% for budgeted Reserve

Note: Exemptions are a result of Veterans and Elderly exemptions granted through Clause 41, 17 & 22. Abatements are the value difference granted due to over assessment as filed during the abatement period.

Sincerely,

Jennifer Bonfiglio

A RESOLUTION ACCEPTING A GRANT FROM THE COMMONWEALTH OF MASSACHUSETTS EXECUTIVE OFFICE FOR ADMINISTRATION AND FINANCE TO THE TOWN OF AGAWAM FOR DIRECT PAY TAX ASSISTANCE PURSUANT TO MASSACHUSETTS GENERAL LAWS CHAPTER 44, SECTION 53A

(Sponsored by Mayor Christopher C. Johnson)

WHEREAS, the Commonwealth's Executive Office for Administration and Finance has awarded the Town of Agawam a FY26 Municipal and Tribal Technical Assistance (MTTA) grant for the Direct Pay Tax Assistance Program; and

WHEREAS, the grant is in the amount of Fifty Thousand (\$50,000.00) Dollars; and

WHEREAS, the grant will be used to cover costs associated with contracting Energy Tax Savers, Inc. to assist with tax related support, specifically filing for Direct Pay under the Inflation Reduction Act of 2022; and

WHEREAS, the grant will specifically be used to claim refundable tax credits for qualifying green energy investments; and

WHEREAS, it is in the best interest of the Town of Agawam to accept said grant.

NOW THEREFORE BE IT RESOLVED, that the Agawam City Council pursuant to M.G.L. c. 44 §53A accepts a grant in the amount of Fifty Thousand (\$50,000.00) Dollars from the Commonwealth of Massachusetts Executive Office for Administration and Finance for the Direct Pay Tax Assistance Program.

DATED THIS ____ DAY OF _____, 2026.

PER ORDER OF THE AGAWAM CITY COUNCIL

Anthony J. Russo, President

APPROVED AS TO FORM AND LEGALITY



Christopher S. Cappucci, Solicitor

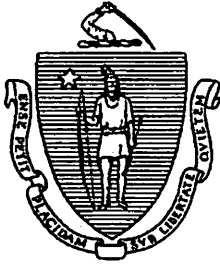

EXECUTIVE OFFICE FOR ADMINISTRATION & FINANCE
COMMONWEALTH OF MASSACHUSETTS
STATE HOUSE - BOSTON, MA 02133
(617) 727-2040

MAURA T. HEALEY
GOVERNOR

KIMBERLEY DRISCOLL
LIEUTENANT GOVERNOR

MATTHEW J. GORZKOWICZ
SECRETARY

February 10, 2026

Christopher C. Johnson
Mayor
Town of Agawam
36 Main Street
Agawam, Massachusetts 01001
cjohnson@agawam.ma.us
CC: Jennifer Bonfiglio, Chief Procurement Officer
jbonfiglio@agawam.ma.us

Re: MTTA Award Letter

Dear Mayor Johnson,

On behalf of the Administration of Governor Maura T. Healey and Lieutenant Governor Kimberley Driscoll, I am pleased to confirm the Commonwealth's award of up to **\$50,000.00** total in funds ("Funds") to **the Town of Agawam** ("Grantee") as authorized under the Municipal and Tribal Technical Assistance program ("MTTA").

The Funds will be administered by the Federal Funds and Infrastructure Office ("FFIO") and represent support for costs associated with technical assistance for federally funded projects ("Project"), including but not limited to researching and pursuing funding opportunities, preparing grant applications, providing procurement services, conducting planning and studies, and assessing capacity.

Disbursement of the Funds **\$50,000.00** will be disbursed to the Grantee within 45 days of execution of the grant contract ("Agreement").

Funds must be expended by **June 30, 2026**. If Funds have not been fully expended by that date, Grantee may request an extension through October 31, 2026.

The receipt of the Funds is contingent upon the Grantee being able to certify that it will comply with the Massachusetts General Laws, including G.L. c. 40A, § 3A, the MBTA Communities Act. Compliance with the MBTA Communities Act is determined by the Executive Office of Housing and Livable Communities.

The Agreement will be sent electronically by the Commonwealth through Adobe Sign for your review and signature.

Thank you and we look forward to further engagement with you on the successful completion of the Project.

Sincerely,

Dana Sullivan

Dana C. Sullivan
Chief of Strategy and Operations
Executive Office for Administration & Finance

Cc: Robert LaRocca, Deputy Director, and Raffi Freedman-Gurspan, Associate Director
Federal Funds & Infrastructure Office, EOAF

TR-2026-26

**A RESOLUTION TO APPROPRIATE FUNDS FOR
THE SUCCESSOR COLLECTIVE BARGAINING AGREEMENT
BY AND BETWEEN THE AGAWAM POLICE PATROLMEN'S ASSOCIATION
AND THE TOWN OF AGAWAM**

(Sponsored by Christopher C. Johnson, Mayor)

WHEREAS, the Town of Agawam has negotiated a successor collective bargaining agreement with the Agawam Police Patrolmen's Association which is memorialized in the document entitled Settlement Agreement by and between the Town of Agawam and the Agawam Police Patrolmen's Association (hereinafter referred to as the "Settlement Agreement"); and

WHEREAS, the Settlement Agreement has been ratified by the Agawam Police Patrolmen's Association; and

WHEREAS, the Settlement Agreement is a three year agreement for the period of July 1, 2025 to June 30, 2028 that provides for the following annual cost of living increases: effective July 1, 2025 (2.5% percent increase); effective July 1, 2026 (2.5% increase); and effective July 1, 2027 (3.0% increase); and

WHEREAS, pursuant to Massachusetts General Laws Chapter 150E, Section 7, the Agawam City Council is required to appropriate the necessary funds; and

WHEREAS, funding for the Agreement was approved as part of the Fiscal Year 2026 Annual Operating Budget and shall be transferred to various salary line items from the Salary Reserve Account in the Line Items section of the Fiscal Year 2026 Annual Operating Budget; and

WHEREAS, it is in the best interests of the Town of Agawam to appropriate the necessary funds for the successor collective bargaining agreement by and between the Town of Agawam and the Agawam Police Patrolmen's Association; and

NOW THEREFORE, BE IT RESOLVED BY THE AGAWAM CITY COUNCIL that the sum of Ninety-Nine Thousand Seventy and 00/100 (\$99,070.00) Dollars shall be appropriated from the Salary Reserve Account in the Line Items section of the Fiscal Year 2026 Annual Operating Budget to be transferred to various salary line items to fund the first year of the successor collective bargaining agreement with the Agawam Police Patrolmen's Association entitled Settlement Agreement by and between the Town of Agawam and the Agawam Police Patrolmen's Association.

Dated this ____ day of _____, 2026.

PER ORDER OF THE AGAWAM CITY COUNCIL

Anthony J. Russo, President

APPROVED AS TO FORM AND LEGALITY



Christopher S. Cappucci, City Solicitor

APPROVED AS TO APPROPRIATION

Cheryl St. John, Auditor

SETTLEMENT AGREEMENT BY AND BETWEEN
THE TOWN OF AGAWAM AND THE
AGAWAM POLICE PATROLMEN'S ASSOCIATION

The Town of Agawam and the Agawam Police Patrolmen's Association hereby agree to the following terms, conditions, and understandings to be incorporated into the successor collective bargaining agreement. This Settlement Agreement is subject to ratification by the respective constituent bodies.

1. **Article 5 Grievance Procedure:** Replace Section 5.8 with the following:

5.8 Expenses for the arbitrator's services shall be paid by the losing party (i.e. the party who is determined on whole to have received a negative decision). In the event of a split decision, both parties will share the expenses for the arbitrator's services equally.

2. **Effective July 1, 2026: Article 8 – Hours of Work:** The parties acknowledge that the "roll call" compensation referenced in Paragraph 8.2 has previously been rolled into the base salary and shall not be a separate payment.
3. **Effective July 1, 2026: Article 10 – Outside Details:** Add the following to the end of Paragraph 10.3:

Any detail exceeding four (4) hours shall be compensated as eight (8) hours. For details not associated with private construction or utility work, including but not limited to assignments at Six Flags New England, the Big E, and any municipal or school-related events such as sporting events, Department of Public Works projects, or concerts, there shall be a minimum compensation of four (4) hours, with any additional time beyond the four-hour minimum compensated at the established hourly detail rate.

The parties agree that there shall be no retroactive payments due for any outside detail work performed after July 1, 2025 through the date the retroactive payments are processed by the Town.

4. **Effective July 1, 2026: Article 11 Holidays:** The existing Article 11 shall be deleted and replaced with the following:

- 11.1 Employees covered by this Agreement shall have the following holidays:

New Year's Day	Memorial Day	Columbus Day
Martin Luther King Day	Juneteenth	Veterans Day
President's Day	4 th of July	Thanksgiving Day
Patriot's Day	Labor Day	Christmas Day

11.2 The total annual holiday pay shall be rolled in the base salary and shall not be a separate payment. An employee who does not work the holiday shall receive no additional pay. An employee who does work the holiday shall be paid an additional half-day's pay.

11.3 Any employee called into work on a holiday which is their regularly scheduled day off shall receive an additional half-day's pay or (double time). An employee after working their regularly scheduled holiday shift, who is held over by the officer in charge, shall receive double time for all time worked after their scheduled shift on a holiday.

11.4 The Association agrees this method of payment for holidays worked is not and will not be raised by it as a violation of the Fair Labor Standards Act.

5. Article 13 – Sick Leave:

Add the following to the end of Paragraph 13.1:

In the event of the illness of an employee's spouse, parent, and/or child, the employee shall be allowed to use their annual sick leave for the purposes of caring for such person. An employee may utilize more than their annual sick leave for the purposes of caring for an ill spouse, parent, and/or child with the advance written approval of the Human Resources Director. The decision of the Human Resources Director shall be final and shall not be subject to the grievance and arbitration procedure outlined in Article 2 or any other appeal.

Rewrite the first sentence of Paragraph 13.3 to read:

In the event of the illness of an employee's spouse, parent, and/or child, the employee shall be entitled to use unpaid leave in accordance with the provisions of the Federal Family and Medical Leave Act of 1993 (F.M.L.A.) (note: the employee may use up to their annual amount of sick leave concurrently with F.M.L.A. leave).

6. Effective July 1, 2026: Article 16 - Clothing Allowance: The second sentence of Paragraph 16.1 shall be amended to read as follows:

The stipend (\$1,100.00) associated with this requirement shall no longer be rolled into longevity and effective July 1, 2025, it shall be rolled in the base salary and shall not be a separate payment.

7. Article 28 – Salary Scale:

Amend the second portion of Paragraph 28.2 to read as follows:

FY2026 (July 1, 2025 to June 30, 2026) – 2.50% increase
FY2027 (July 1, 2026 to June 30, 2027) – 2.50% increase
FY2028 (July 1, 2027 to June 30, 2028) – 3.00% increase

The percentage increases above only apply to the base salary schedules and not to other benefits in the Agreement. Retroactive wage payments shall be made only to bargaining unit members on the payroll at the time the retroactive payment is made.

Amend the last paragraph of Paragraph 28.2 to read as follows:

Officers will be eligible for Step 6 upon completion of three (3) years of continuous service in the Agawam Police Patrolmen's Association. Officers will be eligible for Step 7 upon completion of fifteen (15) years of continuous service in the Agawam Police Patrolmen's Association bargaining unit. Officers will be eligible for Step 8 upon completion of twenty (20) years of continuous service in the Agawam Police Patrolmen's Association bargaining unit.

Add new Paragraph 28.5 to read as follows:

28.5 The parties agree that the Employer shall have the right to start new employees at any step in the salary schedule as set forth on Exhibit A, which is attached hereto and incorporated herein by reference.

8. Article 33 – Duration:

Amend 1st sentence of Paragraph 33.1 to change date to June 30, 2028

Amend 1st sentence of Paragraph 33.3 to change date to October 1, 2027

Amend 2nd sentence of first paragraph of Paragraph 33.3 to change date to March 15, 2028 and FY2029

Amend second paragraph of Paragraph 33.3 to change dated to March 15, 2028

9. Effective July 1, 2026: Article 34 – Firearms Qualification: Amend the note at the end of the 2nd sentence of Paragraph 34.1 to read as follows:

Note: The stipend (\$475.00) associated with this requirement shall no longer be rolled into longevity and effective July 1, 2025, it shall be rolled in the base salary and shall not be a separate payment.

10. Article 36 – Police Career Incentive Pay:

The last portion of Paragraph 36.1 shall be amended to read as follows:

Effective July 1, 2025:	Associates Degree:	5% increase
	Bachelor's Degree:	12.5% increase
	Master's Degree:	15% increase
Effective July 1, 2026:	Associates Degree:	5% increase
	Bachelor's Degree:	15% increase
	Master's Degree:	17.5% increase

A new Paragraph 36.15 shall be added and shall read as follows:

36.15 To qualify for the educational incentives outlined above, the degree shall be earned in an educational institution accredited by the New England Association of Colleges and Secondary Schools or by the Massachusetts Board of Higher Education, and the degree shall be earned in criminal justice or law enforcement.

A new Paragraph 36.17 shall be added and shall read as follows:

36.17 An employee with a degree, or who desires to pursue a degree, in a field of studies other than criminal justice or law enforcement may seek to have their degree or proposed degree be qualified to receive police career incentive pay under this Article by submitting a written request to the Human Resources Director. The decision of the Human Resources Director shall be final and shall not be subject to the grievance and arbitration procedure outlined in Article 2 or any other appeal.

11. Article 37 - Injury on the Job:

Add new Paragraph 37.11 to read as follows:

Any employee who has returned to duty after a period of incapacitation caused by a line of duty injury under Massachusetts General Laws, Chapter 41, Section 111F and who is still undergoing follow up medical care related to said injury, such as doctor's appointments and/or physical therapy, shall make their best efforts to schedule said follow up medical care during their normal work hours. If said follow up medical care takes place outside their normal work hours, the employee shall receive time and one-half compensation for time actually spent receiving said follow up medical care.

Add new Paragraph 37.12 to read as follows:

An employee who is incapacitated because of a line of duty injury shall be considered to be on a temporary Monday through Friday 8:00 A.M. to 4:00 P.M. shift assignment for the purposes of attending doctor's appointments and/or physical therapy sessions or other follow up medical care related to said line of duty injury.

12. Add the following as a new Article entitled "Light Duty" to read as follows:

The Town may require an employee on injured on duty status or may allow an employee injured while off duty, to perform light duty, provided the process outlined below is utilized. Light duty is intended for injured employees who are expected to return to full duty within a reasonable time. Light duty may be required or requested only if the employee's or the Town's medical provider finds that the employee is physically capable of performing the light duty assignment proposed by the Town, examples of which shall be detailed in writing. If the employee's medical provider and the Town's medical provider disagree as to the employee's physical capability for such duty, the employee shall remain out while the employee and the Town shall jointly designate a medical provider agreeable to both, who at the Town's expense, shall examine the

employee and render a written medical opinion as to the employee's fitness to perform the proposed light duty assignment. Such opinion shall be binding on both parties. During the assignment, the procedure described above may be re-established at the request of the Town's or the employee's medical provider.

If an employee has been determined to be capable of performing light duty, and is assigned to light duty, the employee shall be placed on the employee's normal work schedule, unless otherwise mutually agreed upon by the employee and the Town. The Town shall make reasonable accommodations to assist in the rehabilitation of the employee's injury.

Light duty under this Article shall refer to work presently performed by bargaining unit personnel which shall not aggravate or hinder the healing of the employee's injury. To the extent possible, reasonable accommodations shall be made to minimize the perception that the employee is eligible or expected to perform their full duty assignment.

No light-duty assignment shall commence unless the Town has received a report from a medical provider identifying the actions the employee is prohibited from performing. The report shall also include the anticipated date of return to full duty and the date of the next medical appointment.

No employee on light duty shall be held responsible for failure to render emergency assistance. An employee on leave due to an injury on the job shall continue to receive full benefits as outlined in Massachusetts General Laws, Chapter 41, Section 111F during the period of any light duty performed hereunder.

13. Civil Service:

Add the following after the first sentence of Paragraph 6.7: "The appeal in accordance with G.L. Chapter 31 shall only be available for those employees with permanent civil service status."

Remove the reference to "Mass. General Laws, Chapter 31" from the first sentence of Paragraph 9.7.

Amend Paragraph 24.1 to read as follows: "The Employer agrees not to employ any person or persons to perform the duties of a police officer as presently performed by the members of this bargaining unit."

Add new Paragraph 24.2 to read as follows: "The Union agrees that the Town may opt in to the new hybrid pathway through the Commonwealth of Massachusetts Human Resources Division. The hybrid pathway allows the Town to make up to one-half of entry-level police appointments outside of the traditional civil service exam process, drawing from a locally generated pool of prospective candidates. In addition, the Town may appoint full time lateral transfer police officers from other communities, including non-civil service communities, through this process. At the sole discretion of the Chief, full-time lateral transfer police officers may have their years of service with their former police agency counted as time employed by the Town for purposes of placement on the

wage schedule and vacation accrual. Seniority rights under Article 7 shall be based solely on an employee's number of years of credible full time service as a police officer with the Town of Agawam."

14. **New Article(s)**: In recognition of potential new impacts and/or obligations and other changes in terms and conditions of employment as a result of the implementation of the following items, the Town shall increase each employee's base pay by two (2%) percent effective July 1, 2025; by one (1%) percent effective July 1, 2026 and by one (1%) percent effective July 1, 2027:
- (a) The implementation of the Police Reform Act of 2020 (Chapter 253 of the Acts of 2020), and that decertification by a final decision of the Police Officer Standards and Training (POST) Commission shall constitute just cause for termination. The parties agree that "final decision" as used above shall mean after exhaustion of all available means of appeal.
 - (b) The implementation of body worn cameras and/or cruiser cameras, whether or not they are implemented during the life of this Agreement. The Town agrees to involve the Union in the development of policies and procedures for these camera programs.
 - (c) The implementation of GPS technology, whether or not it is implemented during the life of this Agreement.
 - (d) The implementation of policies and procedures to achieve certification and accreditation by the Massachusetts Police Accreditation Commission or any successor organization, whether or not it is achieved during the life of this Agreement.

The Union expressly acknowledges and agrees that the Town has satisfied its bargaining obligations with respect to any and all potential impact on bargaining unit members resulting from the items listed above, whether or not they are implemented during the life of this Agreement.

15. **New Article: New Hires**: In consideration for the Town's investment to pay for an employee's Academy Training and its reimbursement to an employee of up to one thousand five hundred (\$1,500.00) dollars toward uniforms and equipment at the start of Academy Training, any employee who, within three (3) years from the date they are sworn in as a police officer, leaves Town employment to accept another police-related position in Massachusetts or within fifty (50) miles of any Town border, shall reimburse the Town for the full amount paid for the employee's Academy Training and the amount of any reimbursement paid for uniforms and equipment at the start of Academy Training. The Union agrees that it has no objection to the Town implementing policies and practices that will obligate trainees who fail to complete Academy Training to repay the Town for any amounts expended for Academy Training, uniforms, equipment and/or any license to carry permits issued during said training.

Each employee shall serve a twelve (12) month probationary period, during which discipline, demotions, suspensions and/or discharges are not subject to the grievance and arbitration procedure outlined in Article 2 or any other appeal. The probationary period shall commence the first day of full time employment in the bargaining unit as a sworn police officer.

16. JLMC – Compensatory Time: The parties agree to form a Joint Labor Management Committee which shall be comprised of four members with two appointed by the Town and two appointed by the Union to discuss the possible implementation of compensatory time off.

FOR THE TOWN OF AGAWAM



Dated: 03-02-26

FOR THE AGAWAM POLICE
PATROLMEN'S ASSOCIATION

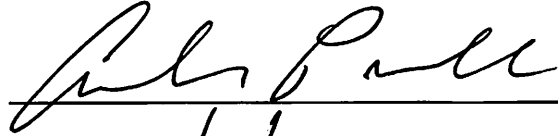

Dated: 3/2/24

**REVISED
TR-2026-27**

**A RESOLUTION TO APPROPRIATE
NINETY TWO THOUSAND (\$92,000.00) DOLLARS
FROM THE MUNICIPAL GOLF STABILIZATION FUND
TO FUND AGAWAM MUNICIPAL GOLF COURSE OPERATIONS ACCOUNTS**

(Sponsored by Christopher C. Johnson, Mayor)

WHEREAS, the Municipal Golf Stabilization Fund currently has a balance of Six Hundred Thirty-Seven Thousand Five Hundred Nine and 93/100 (\$637,509.93) Dollars; and

WHEREAS, the course is doing well in the current fiscal year and several accounts need additional funds to complete Fiscal Year 2026 which ends on June 30, 2026 including temporary salary for seasonal workers, food and beverage sold at the course; grounds and building maintenance and electricity; and

WHEREAS, it is in the best interests of the City of Agawam to appropriate funding from the Municipal Golf Stabilization Fund to allow it to successfully complete Fiscal Year 2026 operations; and

NOW THEREFORE, BE IT RESOLVED by the Agawam City Council that the total sum of Ninety Two Thousand (\$92,000.00) Dollars is hereby appropriated from the Municipal Golf Stabilization Fund to the following line items:

\$ 30,000.00 to	Regular Temporary	Line Item 65261 51020
\$ 50,000.00 to	Food Service Supplies	Line Item 65263 52220
\$ 6,000.00 to	Grounds & Bldg Maint	Line Item 65262 52020
\$ 6,000.00 to	Electricity/Heat	Line Item 65262 52110

Dated this _____ day of _____, 2026.

PER ORDER OF THE AGAWAM CITY COUNCIL

Anthony J. Russo, Council President

APPROVED AS TO FORM AND LEGALITY



Christopher S. Cappucci, City Solicitor



Town of Agawam

Christopher C. Johnson, Mayor
36 Main Street
Agawam, MA 01001
Telephone: 413-786-0400 | 413-786-4520

Memorandum

To: Agawam City Council
From: Christopher C. Johnson, Mayor
Re: TR-2026-27 Revised Golf Stabilization Fund Appropriation
Date: April 16, 2026

The Course Manager has asked to revise the original appropriation request from the Municipal Golf Stabilization Fund by increasing the funding for the Food Service Supplies line item by \$10,000 and increasing the funding for the Grounds & Building Maintenance line item by \$2,000.

The course is experiencing a tremendous start to the season, and the Course Manager has recently booked several large tournament outings for May and June. In order to have sufficient funding to meet this increased demand, additional funding is necessary in the Food Services Supplies line item. In addition, additional funding is needed in the Grounds & Building Maintenance line item to secure repairs to several pieces of equipment.

The Municipal Golf Stabilization Fund currently has a balance of over \$637,000 and the Course Manager anticipates closing the current fiscal year with another revenue surplus.

Please do not hesitate to contact me with any questions.

Very truly yours,



Christopher C. Johnson
Mayor

April 2, 2026

Mayor Christopher Johnson
36 Main Street
Agawam, Ma. 01001

Dear Mayor. Johnson,

I would like to appropriate **\$80,000.00** from our Golf Stabilization account. Our Golf Stabilization account presently is at **\$637,50.00..**

- **\$30,000.00 Into Temporary Labor [65261-51020]**
- **\$40,000.00 Into Food/Beverage [65263-52220]**
- **\$4000.00 Into Grounds/ Building [65262-52020]**
- **\$6000.00 Into Electricity [65262-52110]**

This transfers is necessary because temporary labor funding is low with the extended season and an early opening.

The remaining funds in my food/beverage account is not enough to support the anticipated business through June 30th.

The Grounds/Building account is low as well as the electricity account.

Sincerely,

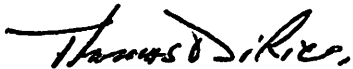

Thomas DiRico, PGA

Director of Golf/GM

Agawam Municipal Golf Course

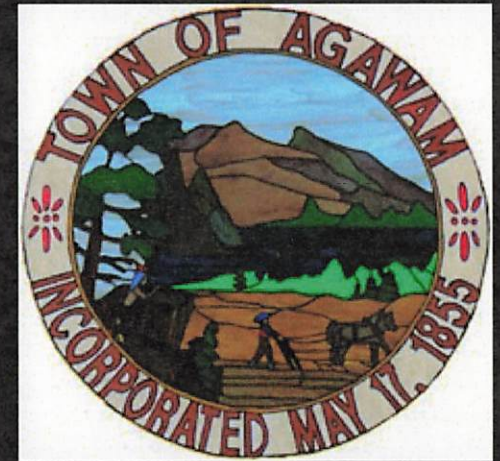

CAPITAL IMPROVEMENT PROGRAM

FISCAL YEAR 2027 – FISCAL YEAR 2031



Capital Improvement
Program
FY2027 – FY2031

TABLE OF
CONTENTS

<u>Item</u>	<u>Page No.</u>
Cover Memorandum to City Council	1
Introduction	2
Debt Management Policy	6
Project Descriptions	9
Capital Improvement Appropriations.....	31
Capital Improvement New Bonds.....	36
Chart - Annual Appropriations	37
Chart - General Fund Existing Bond Costs	39
Chart - General Fund Existing & New Bond Costs	41
Chart – Self Sustaining Depts Existing Bond Costs	43
Chart – Self Sustaining Depts Existing & New Bond Costs..	45
Useful Life – Town & School Buildings.....	47



Capital Improvement
Program
FY2027 – FY2031

COVER MEMO
TO CITY COUNCIL

Memorandum

To: Agawam City Council
From: Christopher C. Johnson, Mayor
Date: April 6, 2026
Subject: Capital Improvement Program (FY 2027-2031)

Pursuant to Section 5-3 of the Agawam Home Rule Charter, I hereby submit the Capital Improvement Program for Fiscal Year 2027 to Fiscal Year 2031 to the Agawam City Council. The Capital Improvement Program is a prioritized plan of proposed capital improvements over the next five fiscal years.

The major purpose of the Capital Improvement Program is:

- ▶ to develop and prioritize needed capital improvement projects;
- ▶ to research and estimate the revenue necessary to fund proposed capital improvement projects;
- ▶ to set parameters on the revenue dedicated to fund proposed capital improvement projects; and
- ▶ to forecast future principal and interest expenditures.

The program represents a realistic financially feasible long term program to undertake the capital projects needed by the city. I have worked closely with the department heads to examine the needs of their departments and to provide a plan to meet those needs. Through this cooperative effort, I am confident this Capital Improvement Program will meet the needs of the city. As revenue estimates become available, any revisions to proposed annual appropriations will be reflected in the capital budget portion of the annual operating budget.

Please call with any questions. Thank you.

Respectfully submitted,

Christopher C. Johnson
Mayor



Capital Improvement
Program
FY2027 – FY2031

INTRODUCTION

2

INTRODUCTION

For the purposes of this Capital Improvement Program, a capital improvement is a project or undertaking, which provides for (i) the planning, design, construction, reconstruction, renovation or replacement of a public building, facility, vehicles or equipment; (ii) an addition to a public building or facility; (iii) the purchase of land, buildings or facilities for a public purpose; or (iv) a long range development study. While the type of improvement is the basic criteria, a project costing at least \$25,000 that has a life expectancy of five (5) years or more is generally considered to be a capital improvement.

The Capital Improvement Program is designed to accomplish the following purposes:

1. to utilize city funds for capital improvements which are compatible with the city's mission of effective and efficient provision of quality services to the citizens and businesses of Agawam which in turn enhances the quality of life in our community;
2. to prioritize the undertaking of capital improvement projects on a coordinated basis;
3. to inform the community when needed of planned capital improvement projects and corresponding expenditures expected to be initiated in the future;
4. to utilize city funds on the basis of community priorities in coordination with the availability of grants and/or other state, federal or private reimbursements; and
5. to undertake capital improvements after careful planning and financial analysis to avoid an undue burden on the taxpayers and a strain on the city's fiscal capacity now and in the future.



Capital Improvement
Program
FY2027 – FY2031

INTRODUCTION
(CONTINUED)

3

The city has recently undertaken many significant capital improvement projects such as the construction of a new high school, a new police headquarters, extensive renovations to the public library and the creation of Still Brook Park in Feeding Hills. The new high school will also include a new early childhood center. These projects were undertaken in spite of projected limited revenue growth. Fiscal restraint and careful planning are required to assure long-term financial stability, and care must be taken in project development and implementation in order that bond sales are timed, so that principal and interest costs occur in the year scheduled.

In developing this Capital Improvement Program, the following general assumptions on fiscal capacity were assumed and applied:

1. growth in total property tax revenues will continue to be limited by the restraints of Proposition 2½ and a debt exclusion override was approved by the voters of Agawam for the new high school project which will allow the community to maintain financial flexibility in the future;
2. the city has the option to pursue the maximum property tax revenue allowed by Proposition 2½ (Agawam currently has over \$18.5 million dollars in excess levy capacity);
3. given the significant cost of the new high school project, the Administration will recommend delaying the pursuit of other significant general fund capital improvement projects to minimize the impact on future tax rates;
4. during the next five years, the city should:
 - a. appropriate as much funding as possible annually from the general fund for smaller capital improvement projects on a pay as you go basis while maintaining existing service levels; and
 - b. utilize the newly created Capital Stabilization Fund to assist in meeting the above referenced goal and to blunt the impact of future bond payments for the high school.



Capital Improvement
Program
FY2027 – FY2031

INTRODUCTION
(CONTINUED)

4

The process of capital planning involves setting priorities within the fiscal capability of the city. Each year the entire plan is reviewed in light of changing needs and requirements. There are more needs for improvements by city departments that can be included in the five year time period.

In developing this Capital Improvement Program, the following priorities were addressed:

1. Infrastructure Reliability - the city must meet the utility (specifically water, wastewater and stormwater) needs of its residents and businesses through the timing of public utility replacement, modernization and expansion;
2. Improve or Assist Service Delivery - projects that will reduce the need for staff increases or make staff operations more efficient have been given priority;
3. Facilities - New and Maintenance of Existing Facilities - when Proposition 2½ was implemented, communities were forced to delay constructing new facilities and defer maintenance on existing facilities which has led to a backlog of need for new facilities and the maintenance and renovation of existing facilities; and
4. Prior Commitments - the city is bound by commitments made in prior years, and those commitments were considered in this program.



Capital Improvement
Program
FY2027 – FY2031

INTRODUCTION
(CONTINUED)

5

This Capital Improvement Program was developed around the previously cited constraints and program objectives. It includes a bonding and appropriation plan for each of the five program years, a brief description of each project, spread sheets and charts showing existing and proposed bond payments and graphical representations of these payments.

Long Term Considerations: While this Program contains a detailed plan for the next five fiscal years, there are several long term considerations that assist in the decision making process. They are the following:

- a. Schools – the Town is currently building a new high school, which will include a new early childhood center. There are six other school buildings that range in age from 50 to 100 years. It is a long term goal to extend the useful life of each of the remaining school building for another 25 years, more or less, which would allow for the future construction of a single K-8 facility to replace the existing six buildings. The elementary schools roof project is an example of a capital improvement designed to extend the useful life of those buildings.
- b. Public Safety – the Town recently completed construction of a new police headquarters which should have a fifty year useful life. The fire headquarters is approximately thirty years old with an estimated useful life of another thirty plus years. Expansion of the fire headquarters will likely be necessary in the next ten years. Fire Station 2 has a much shorter expected useful life, and will likely need to be renovated or replaced in the next 10-15 years.
- c. Other Needs – the Town Hall is nearing its 100th anniversary. The building is well constructed but poorly laid out for the modern operation of our local government. There will be some cosmetic work done to the interior to freshen the offices and bathroom facilities. The town is currently looking at window replacement. Ultimately, the Town Hall will need to be renovated or replaced in the next 10-20 years.



Capital Improvement
Program
FY2027 – FY2031

DEBT MANAGEMENT POLICY

6

DEBT MANAGEMENT POLICY

A. Introduction

The use of long-term debt (debt with a repayment schedule longer than 12 months) via the issuance of municipal bonds is a necessary way for Agawam to address major facility, infrastructure and equipment needs. It allows the city to spread the cost of significant capital projects over a longer period of time. If the city accumulates too many bond obligations, the burden on taxpayers can become so great that it becomes difficult to pay both the city's annual operating costs and its annual debt service obligations. Great care and planning must be taken when incurring long-term debt to avoid placing an undue strain on future revenues, and potentially jeopardizing the city's ability to fund essential services. The purpose of this policy is to establish guidelines governing the use of long-term debt and demonstrate the city's commitment to full and timely repayment of all long term debt issued.

Massachusetts General Laws regulate the purposes for which municipalities may incur debt, and the maximum maturity for bonds issued for different municipal purposes. M.G.L. Chapter 44 specifies that the debt limit for communities is five percent of its equalized valuation as determined by the Commonwealth. The equalized valuation for Agawam for 2024 (the latest year set by the Commonwealth) was \$4,389,799,200. Based upon that equalized valuation, Agawam's debt limit would be approximately \$220 million. Please note that school projects approved by the Massachusetts School Building Authority fall outside the debt limit.

Massachusetts General Laws allow communities, subject to voter approval, to exclude certain debt from the limits imposed by Proposition 2½. A voter-approved exclusion for the purpose of raising funds for debt service costs is referred to as debt exclusion. Agawam received voter approval of a debt exclusion for the debt service costs associated with the new Agawam High School Project. The debt exclusion will allow the city to maintain financial flexibility in the future which will avoid the city potentially being forced to seek an override of Proposition 2½ to fund essential services in future annual operating budgets.



Capital Improvement
Program
FY2027 – FY2031

DEBT
MANAGEMENT
POLICY
(CONTINUED)

7

B. Capital Improvement Program

The city has established and maintains a five (5) year Capital Improvement Program (CIP), including all proposed projects and major pieces of equipment that may require long term debt financing. The city's long-term debt strategies are structured to reflect its capital needs and ability to pay.

C. Bond Rating

Agawam currently has a bond rating of AA from Standard & Poor's. Agawam has a short term credit rating of SP1+ from Standard & Poor's which is the highest level of short term creditworthiness. A community's bond and credit ratings are important because they are major factors in determining the rate of interest a community pays when issuing bonds, as well as the level of market participation (number of bidders). All things being equal, the higher the bond and credit ratings, the lower the interest rate. Bond analysts (e.g. Moody's, Standard & Poor's, Fitch) typically look at four sets of factors in assigning a bond or credit rating:

Debt Factors: debt per capita, debt as a percentage of equalized valuation, rate of debt amortization and the amount of exempt versus non-exempt debt.

Financial Factors: operating surpluses or deficits, free cash as a percent of revenue, state aid reliance, property tax collection rates, unfunded pension and OPEB liability.

Economic Factors: property values, personal income levels, tax base growth, tax and economic base diversity, unemployment rates and population growth.

Management Factors: governmental structure, the existence of a capital improvement plan, the quality of accounting and financial reporting, etc.

The city continually strives to maintain its bond rating through sound financial management, receivables management, accounting and financial reporting, and increased reserves such as the Stabilization Fund and the Capital Stabilization Fund.



Capital Improvement
Program
FY2027 – FY2031

**DEBT
MANAGEMENT
POLICY**
(CONTINUED)

8

D. Debt Guidelines

General Fund Debt Service: A limit on debt service costs as a percentage of the city's total budget is especially important because of Proposition 2½ constraints on the city's budget. At the same time, the community's regular and well-structured use of long-term debt signifies the municipality's commitment to maintaining and improving its infrastructure. Municipal credit analysts often use 10% as a maximum benchmark for financial soundness. Agawam will, by policy, establish a debt service ceiling of 10%, meaning that annual debt service payments on bonded debt should not exceed 10% of the annual operating budget (e.g. - maximum debt service payments of \$13.75 million in Fiscal Year 2026). The city will also, by policy, establish a debt service floor of 2% (e.g. - \$2.75 million in Fiscal Year 2026) as an expression of support for continued investment in the city's public facilities, infrastructure and other capital assets.

Debt Maturity Schedule: As previously stated, Massachusetts General Laws Chapter 44 specifies the maximum maturity for bonds issued for various municipal purposes. A city may choose to borrow for a shorter period than allowed by the statutory limit. A reasonable maturity schedule not only reduces interest costs but balances the need to continually address capital improvements. The city will, by policy, establish a goal of issuing debt for shorter periods than the maximum allowable when the statutory limit exceeds 10 years. Exceptions may be made when grants, reimbursements or other situations warrant.

E. Debt Strategies

Alternative Financing Strategies: The city will continually pursue opportunities to facilitate capital projects and acquire capital by means other than conventional borrowing; such as grants, and low or zero interest loans from state agencies such as the Massachusetts Clean Water Trust (MCWT), Massachusetts School Building Authority (MSBA) or the Massachusetts Water Resources Authority (MWRA).

Debt Issuance: The city will work closely with its Financial Advisor and Bond Counsel to ensure that all legal requirements are met and that the lowest possible interest rate can be obtained. This includes preparation of the all-important disclosure document (official statement).



Capital Improvement
Program
FY2027 – FY2031

**PROJECT
DESCRIPTIONS**
RECURRING CAPITAL NEEDS

9

PROJECT DESCRIPTIONS

The city will strive to provide approximately \$2.5 million dollars of annual appropriations for smaller or recurring capital needs of the community. The following are the recurring capital needs to be funded by annual appropriations as part of the city's annual operating budget:

I. RECURRING CAPITAL NEEDS

STREET AND INFRASTRUCTURE IMPROVEMENT PROGRAM

Funding is required for the improvement and maintenance of our local streets. Municipal street projects include the construction, reconstruction, widening, resurfacing of roads, maintenance of historic street lights, repair and installation of guard rails, repair of culverts and drainage systems, catch basin cleaning, trimming and/or removing diseased and dead trees on city property, repair and paving of city owned property and related work in the city's rights of way, pavement marking and signage. Appropriations will be supplemented with Chapter 90 funds from the Commonwealth to enhance pavement management and the Complete Streets program.

street paving



crack sealing



pavement marking





Capital Improvement
Program
FY2027 – FY2031

PROJECT
DESCRIPTIONS
RECURRING CAPITAL NEEDS

10

Pavement Management includes:

Pavement Reconstruction: including but not limited to milling of top course pavement layer, installation of a crack reducing materials, overlay of new bituminous asphalt and full-depth reclamation and pavement reconstruction;

Pavement Preservation/Management: including, but not limited to fog sealing, crack sealing, chip sealing, cape sealing, micro surface or similar asphalt surface treatment application, and any other work related to pavement preservation;

Related Work: any work needed to accomplish pavement reconstruction or maintenance items such as street sweeping, tack coating, pavement markings, saw cutting, driveway apron installation, berm/curbing adjustment or installation, police/traffic management detail, etc.;

Engineering Design or Pavement Management Related Work: any work relating to the management, survey, design, or layout of pavement projects including, but not limited to right of way takings and pavement management programs/studies; and

Utility Structure Adjustments and Upgrades: utility adjustments required as a result of pavement projects including, but not limited to manhole, catch basin, water gate, hydrant and other related infrastructure adjustments or upgrades.



Capital Improvement
Program
FY2027 – FY2031

PROJECT
DESCRIPTIONS
RECURRING CAPITAL NEEDS

11

SIDEWALK REHABILITATION AND EXTENSION

Continuing implementation of a cost effective means to address deteriorating sidewalks and ensure compliance with the Americans with Disabilities Act to provide curb ramps and fulfill the sidewalk rehabilitation requirements as outlined in the city's Complete Streets Policy, a dedicated annual stream of revenue is proposed specifically to repair, rehabilitate and replace sidewalks. Funds will be used for material to repair, replace and construct new ADA compliant sidewalks. Funds are also included to remove trees that are impacting sidewalks impairing our ability to repair and/or replace sidewalks.

sidewalk rehabilitation



traffic light improvements



TRAFFIC LIGHT IMPROVEMENTS

Annual appropriation of funds to provide for upgrades of equipment and software for existing traffic lights. As older lenses are burning out, the Department of Public Works has implemented a policy to replace them with brighter more energy efficient LED lamps.



Capital Improvement
Program
FY2027 – FY2031

PROJECT
DESCRIPTIONS
RECURRING CAPITAL NEEDS

12

DEPARTMENT OF PUBLIC WORKS VEHICLES & EQUIPMENT

An annual capital appropriation is included to provide for on-going replacement of equipment on a scheduled maintenance program. Funds may be carried from one fiscal year to the next in order to provide funding for large, high value, Department of Public Works trucks and other capital equipment.

FIRE DEPARTMENT MOTOR VEHICLES & EQUIPMENT

An annual capital appropriation is proposed to provide for on-going replacement of equipment on a scheduled maintenance program. Funds may be carried from one fiscal year to the next in order to provide funding for large, high value, Fire Department vehicles and other capital equipment. Please note that ambulances are funded entirely from the city's ambulance fund, and the Council is currently being asked to approve an appropriation and potential borrowing to purchase two new fire engines.



BUILDING MAINTENANCE DEPARTMENT VEHICLES & EQUIPMENT

An annual capital appropriation is proposed to provide for on-going replacement of equipment on a scheduled maintenance program. Funds may be carried from one fiscal year to the next in order to provide funding for large, high value, Building Maintenance vehicles and other capital equipment.

POLICE DEPARTMENT VEHICLES

Police replacement vehicles are appropriated as part of the Police Department annual operating budget.



Capital Improvement
Program
FY2027 – FY2031

PROJECT
DESCRIPTIONS
SMALL CAPITAL PROJECTS

13

II. SMALL CAPITAL PROJECTS

The following are smaller capital projects which may be funded by annual appropriations as part of the annual operating budget:

NETWORK INFRASTRUCTURE MODERNIZATION (Fiscal Year 2027)

Funds for a comprehensive modernization of all municipal networking infrastructure. This is designed to improve system reliability, strengthen cybersecurity, increase bandwidth capacity and ensure long term reliability. The Town's current network operates on switch families that are officially end of sale and end of service life, meaning that they longer receive manufacturer support or updates. As a result, there are elevated security risks. Project calls for replacement of existing HP switches with Aruba CX switches with centralized management through Aruba Central. Estimated cost is \$200,000.



JUNIOR HIGH SCHOOL FLOORING REPLACEMENT(Fiscal Year 2027)

Funds for replacement of failing sections of existing epoxy floor system on first floor of Junior High School with luxury vinyl tile (LVT). The existing flooring is failing, resulting in uneven surfaces, trip hazards and poor appearance. The floor replacement is required for safety and aesthetic reasons. Project will involve repair of existing substrate, priming the entire floor area, application of skim coat materials and installation of the new LVT flooring. Estimated cost is \$135,000.

FIRE HQ GENERATOR (Fiscal Year 2027)

Back-up Generator for Fire Headquarters. Estimated Cost is \$55,000.



Capital Improvement
Program
FY2027 – FY2031

PROJECT DESCRIPTIONS

SMALL CAPITAL PROJECTS

14

FIRE DEPARTMENT – FIRE RESCUE BOAT (Fiscal Year 2027)

Funds for replacement of the department's rescue boat which is nearly 30 years old, with a pitted hull and aging components that threaten mission readiness. Replace it with a modern craft featuring updated SAR technology and safer design will significantly enhance water rescue capabilities. Estimated cost is \$105,000.



FIRE DEPT: DISPATCH OPERATIONS IMPROVEMENTS (Fiscal Year 2028)

Funds for acquisition and implementation of new computer hardware and software that streamlines the movement of vital dispatch data to first responders. This new system allows a dispatcher to simply input the caller's incident data into the computer aided dispatch system, select the units for response and with the push of a button, those units are automatically and instantly notified of the incident location and call nature. This will enhance response efficiency and improve incident outcomes. Estimated cost is \$225,000.

FIRE HEADQUARTERS ROOF REPLACEMENT (Fiscal Year 2028)

Funds for replacement of the shingle roof system on the Fire Headquarters on Main Street. The roof is original to the building and is approximately 30 years old. While it has been one of the most durable and trouble free roofs amongst the city and school buildings (because it is a pitched roof), the shingles are nearing the end of their useful life and should be replaced. Estimated cost is \$245,000.



Capital Improvement
Program
FY2027 – FY2031

PROJECT
DESCRIPTIONS
SMALL CAPITAL PROJECTS

15

FEASIBILITY STUDY - RECREATION CENTER AT PERRY LANE PARK (Fiscal Year 2028)

Funds to prepare a feasibility study and plans to construct a recreation center at Perry Lane Park. As part of the Agawam High School Project, a new Early Childhood Center will be created on the new high school campus. The city would plan to move its Parks and Recreation offices to the existing building at Perry Lane Park. The existing building could be renovated to provide small event spaces. The feasibility study would encompass renovations to the existing building and the potential construction of a gymnasium building on site. Estimated cost is \$125,000.



NEW TELEPHONE SYSTEM (Fiscal Year 2028)

Funds to replace existing on-premises PBX phone system with a modern cloud hosted PBX solution. The current system relies on controllers located in various town and school facilities that are beyond their recommended service life, making it increasingly difficult to repair and support. New system will be cloud based for greater redundancy and reliability. Estimated cost is \$75,000.

FIRE HEADQUARTERS HVAC UPGRADE (Fiscal Year 2028)

Funds for comprehensive replacement of aging HVAC equipment and controls, including three air handling units, two condensing units, one boiler and associated building automation system controls. Existing equipment is original to the late 1990's building and has reached the end of its serviceable life. The new system will be more energy efficient and reliable. Estimated cost is \$160,000.



Capital Improvement
Program
FY2027 – FY2031

PROJECT DESCRIPTIONS

SMALL CAPITAL PROJECTS

16

DPW FACILITY BOILER REPLACEMENT (Fiscal Year 2029)

Funds for replacement of the boilers at the DPW Facility with high efficiency low mass boilers. The existing boilers are 40 plus years old and require frequent maintenance and repairs. Estimated cost is \$170,000.



TOWN BUILDING AUTOMATION UPGRADE (Fiscal Year 2029)

Funds for upgrading the Energy Management Systems at the Agawam Senior Center and Fire Headquarters. The current software is outdated and will soon lose vendor support. The upgrade will allow Building Maintenance to maintain control over the HVAC systems. Estimated cost is \$25,000.00

FIRE STATION PAVING (Fiscal Year 2029)

Funds to repave parking lots at Fire Headquarters and Station 2. Estimated cost is \$225,000.

FIRE DEPARTMENT FURNITURE REPLACEMENT (Fiscal Year 2029)

Funds to replace aging furniture at Fire Headquarters and Station 2. Estimated cost is \$55,000.

DOERING SCHOOL HALLWAY FLOORING REPLACEMENT (Fiscal Year 2030)

Funds to replace aging vinyl composition tile in hallways with new luxury vinyl tile. Existing floor is chipping and deteriorating. Estimated cost is \$235,000.



Capital Improvement
Program
FY2027 – FY2031

PROJECT DESCRIPTIONS

SMALL CAPITAL PROJECTS

17

FIRE DEPARTMENT OVERHEAD DOOR REPLACEMENT (Fiscal Year 2031)

Funds for overhead door replacement at both fire stations. The overhead doors at Fire Headquarters will be nearly 35 years old by FY2031 and the doors at Station 2 are even older. They are showing signs of wear, mechanical failure, and poor insulation. Replacing them with modern, insulated, and faster-operating doors will improve energy efficiency, reduce maintenance downtime, and enhance response times and personnel safety during apparatus deployment. Estimated cost is \$180,000.



FIRE DEPARTMENT RADIO INFRASTRUCTURE IMPROVEMENTS (Fiscal Years 2030 and 2031)

Funds to build a new radio tower to maintain reliable radio communications throughout the community. Our existing system is stretched and a new tower will be needed to insure reliable service. In addition, the existing portable, mobile and dispatch radio equipment needs to be upgraded and migrated to a new digital network for our current VHF analog system. Estimated cost is \$1,100,000.



Capital Improvement
Program
FY2027 – FY2031

PROJECT
DESCRIPTIONS
LARGE CAPITAL PROJECTS

18

III. LARGE CAPITAL PROJECTS

ELEMENTARY SCHOOL ROOF REPLACEMENT (Fiscal Year 2027)

The Town submitted statements of interest to the MSBA for each roofing project in an effort to secure some state assistance for the project. The Town was accepted into the MSBA Accelerated Repair Program which will reimburse the Town for approximately one-half of the cost of the projects. The timeline set by MSBA for the projects will be design in late 2026 with construction to follow in the 2027 construction season. Total estimated cost is \$5,450,000. The following are descriptions for each roof project:

SAPELLI ELEMENTARY SCHOOL ROOF

Funds for replacement of asphalt shingle and rubber membrane roofing systems and building waterproofing. The current roof system is 28 years old and is exhibiting signs of age with maintenance becoming more frequent as the membrane becomes more brittle. This is driving up maintenance costs required to maintain the building as weather tight. Treating the masonry will greatly diminish water and moisture issues from arising in the building. Estimated cost is \$1,450,000.



PHELPS ELEMENTARY SCHOOL ROOF

Funds for replacement of asphalt shingle and rubber membrane roofing systems, gutter repair/replacement, sheathing upgrades, limited window enhancements and building waterproofing. The existing roofing materials were installed in 1997 and are nearing the end of their useful life. The gutter system needs to be upgraded to a larger diameter to remove rainwater, this has become an issue with recent storms that have impacted the city, water has nowhere to go and is pooling around the foundation and being absorbed into the masonry. Building waterproofing will help address water and moisture problems in the facility. Estimated cost is \$1,225,000.





Capital Improvement
Program
FY2027 – FY2031

**PROJECT
DESCRIPTIONS**
LARGE CAPITAL PROJECTS

19

GRANGER ELEMENTARY SCHOOL ROOF

Funds for replacement of asphalt shingle, rubber membrane and slate roofing systems, building waterproofing, drainage upgrades, and dormer restoration. The newest roofing materials were installed in 1997 and have nearly reached their end of their useful life. Building waterproofing needs to be applied to repel water and moisture from entering the building, grading and drainage upgrades are needed to pull water away from the foundation. Small upgrades to the entrance dormers are requested to address moisture issues. Estimated cost is \$1,425,000.



CLARK ELEMENTARY SCHOOL ROOF

Funds for replacement of the rubber membrane roofing system, building waterproofing and drainage upgrades. The roof was installed in 1997 and has nearly reached the end of its useful life. Building waterproofing needs to be applied to repel water and moisture from entering the building, grading and drainage upgrades are needed to pull water away from the foundation. Estimated cost is \$1,350,000.



Capital Improvement
Program
FY2027 – FY2031

**PROJECT
DESCRIPTIONS**
LARGE CAPITAL PROJECTS

20

DOERING SCHOOL ROOF REPLACEMENT (Fiscal Year 2030)

Funds for replacement of the rubber membrane roofing system, building waterproofing and drainage upgrades. The roof was installed on or about 2004 and is nearing the end of its useful life. Building waterproofing needs to be applied to repel water and moisture from entering the building, grading and drainage upgrades are needed to pull water away from the foundation. Estimated cost is \$1,850,000.



DPW BUILDING ROOF REPLACEMENT (Fiscal Year 2030)

Funds for replacement of the rubber membrane roofing system, building waterproofing and drainage upgrades. The roof was installed on or about 2004 and is nearing the end of its useful life. Building waterproofing needs to be applied to repel water and moisture from entering the building, grading and drainage upgrades are needed to pull water away from the foundation. Estimated cost is \$1,850,000.



Capital Improvement
Program
FY2027 – FY2031

PROJECT
DESCRIPTIONS
EXISTING APPROVED PROJECTS

21

IV. EXISTING APPROVED PROJECTS THAT ARE IN PROCESS OF COMPLETION

AGAWAM HIGH SCHOOL PROJECT (including a new Early Childhood Center)

The Council approved a bond authorization in the amount of \$230,245,504 for the design, construction and equipping of a new high school and the voters approved a debt exclusion override on June 11, 2024. The city will receive approximately \$100 million dollars in reimbursement from the Massachusetts School Building Authority for the project. The first phase (Community Wing) of the project is currently underway with a substantial completion date anticipated in December of 2026. The second phase (Academic Wing) will begin in January of 2027 with a substantial completion date of September 0f 2028. Final demolition and construction of new athletic fields is anticipated by late 2028 or early 2029. The new Early Childhood Center is anticipated to be completed by the fall of 2028.





Capital Improvement
Program
FY2027 – FY2031

PROJECT
DESCRIPTIONS
EXISTING APPROVED PROJECTS

22

Gymnasium



Agawam High School Building Project Agawam, MA **FONTAINE BROS.** LeftField **FLANGSBURGH**

Auditorium



Agawam High School Building Project Agawam, MA **FONTAINE BROS.** LeftField **FLANGSBURGH**



Cafeteria



Agawam High School Building Project Agawam, MA **FONTAINE BROS.** LeftField **FLANGSBURGH**

Community Entry



Agawam High School Building Project Agawam, MA **FONTAINE BROS.** LeftField **FLANGSBURGH**



Capital Improvement
Program
FY2027 – FY2031

PROJECT
DESCRIPTIONS
EXISTING APPROVED PROJECTS

23

VETERANS MEMORIAL AT SCHOOL STREET PARK

The Veterans Memorial at School Street Park is nearing completion with the new bell tower expected to be completed by Memorial Day this year. The Veterans Council is gathering names for the latest memorial.





Capital Improvement
Program
FY2027 – FY2031

PROJECT
DESCRIPTIONS
EXISTING APPROVED PROJECTS

24

SUFFIELD/COOPER/ROWLEY STREET INTERSECTION

This project is expected to be completed during the 2026 construction season. The Town received nearly \$1 million dollars in funding from the Commonwealth through the Casino Mitigation Fund and the balance of funding was approved as part of the FY2026 Annual Operating Budget. Work includes realignment of the intersection, new traffic signals, western turn lane on Suffield Street north, new ADA compliant actuated pedestrian crosswalks and a mill and overlay of the area.



MAPLE STREET SAFE ROUTE TO SCHOOLS PROJECT (State Project)

The State expects to complete the Safe Route to Schools Project on Maple Street during the 2026 construction season.



Capital Improvement
Program
FY2027 – FY2031

PROJECT DESCRIPTIONS

ENTERPRISE FUNDS

25

V. ENTERPRISE FUNDS

PUBLIC WORKS – WASTEWATER



WASTEWATER DEPARTMENT EQUIPMENT REPLACEMENT

An annual capital appropriation is included to provide for the ongoing replacement of equipment on a scheduled maintenance program. Funds may be carried from one fiscal year to the next in order to provide funding for high value, large water capital equipment.

SEWER SYSTEM INFILTRATION/INFLOW EVALUATION SURVEY

This evaluation is mandated by MassDEP to follow up on the infiltration/inflow (i/i) study conducted in 2017 that identified areas of the sewer system that have levels of i/i that exceed MassDEP standards. The survey will examine in depth to identify where i/i is entering the system and develop remediation strategies to reduce i/i to meet or exceed the MassDEP standards. Phase A of survey will include smoke testing, dye/flood testing, manhole and pipeline inspections with an estimated cost of \$218,350. If required, Phase B of the survey will involve home inspections and more in depth investigations to determine i/i sources with an estimated cost of \$325,000.00.

MAIN STREET AREA SEWER REHABILITATION

Design and rehabilitation of existing 100 year old sanitary sewer main. Project limits are from approximately Cooper Street to Leonard Street. Work includes pipe replacement, lining and grouting in various sections of the project. Working with various contractors to investigate pipe condition via CCTV and ground penetrative radar. The city was awarded an earmark from the Commonwealth for \$1,500,000 to supplement the work in this area. Estimated design cost is \$300,000 and estimated construction cost is \$3,000,000 with the town's portion being \$1,500,000.



Capital Improvement
Program
FY2027 – FY2031

**PROJECT
DESCRIPTIONS**
ENTERPRISE FUNDS

26

SCHOOL STREET ODOR CONTROL & STATION IMPROVEMENTS

Construction of an odor control facility at the School Street Pump Station to treat problematic hydrogen sulfide odors emanating from the station. Work will also include replacement of pump motors, generator, land taking, fencing and masonry repairs with this project. Estimated cost is \$2,310,000.

SANITARY SEWER REPLACEMENT – BELVIDERE & BROOKLINE

Design of the sewer main replacement for Brookline and Belvidere Streets. This neighborhood has a history of sewer blockages and the city has applied for State Revolving Fund (SRF) loan for the estimated project construction costs, but these funds cannot be used for design. This project is in addition to the water main replacement and drainage replacement proposed under a separate SRF application. The lining of approximately 2,400 feet of root impacted sanitary sewer line will provide resiliency to the sanitary sewer system, reduce the potential for sewer backups and improve the overall condition of the sanitary sewer system, and reduce the treatment of non-wastewater due to reduced inflow and infiltration into the system. Estimated design cost is \$70,000.00.

INFILTRATION/INFLOW SEWER SYSTEM ABATEMENT

Upon completion of the sewer system infiltration study, the city will have identified areas that need repairs or replacement. There is no reliable estimate at this time for the needed work.



Capital Improvement
Program
FY2027 – FY2031

**PROJECT
DESCRIPTIONS**
ENTERPRISE FUNDS

27

WASTEWATER AND WATER JET/VAC TRUCK

Purchase of a new sewer vacuum & jetter truck to permit vacuuming of debris and the construction of a sanitary solids recovery station for handling the vacuumed material from the sewer lines. This will permit removal of solids such as rag, grease and sediment during routine system maintenance. This will reduce blockages, backups and overflows while also minimizing the possibility of corrosive gas formation that damages the sewer infrastructure. Total estimated cost is \$650,000 which will be split by the Wastewater and Water Departments.



PUBLIC WORKS - WATER

WATER DEPARTMENT EQUIPMENT REPLACEMENT

An annual capital appropriation is included to provide for the ongoing replacement of equipment on a scheduled maintenance program. Funds may be carried from one fiscal year to the next in order to provide funding for high value, large water capital equipment.



Capital Improvement
Program
FY2027 – FY2031

PROJECT
DESCRIPTIONS
ENTERPRISE FUNDS

28

WATER METER REPLACEMENT

Purchase and installation of new water meters over a 6 year period. Currently in year two of our meter replacement program which includes meter reading base stations, as well as the analytics software system to view and analyze the data. The system reads and records the water meter usage and monitors system pressure constantly. The system will make it easier to detect water main breaks and discover anomalies in water usage which will ultimately lead to a reduction in the amount of lost water in the system. Estimated cost is \$300,000 per year.

WATER MAIN REPLACEMENT – MAIN STREET

The water main replacement for Main Street was identified by Tighe & Bond using a hydraulic model of the city's water distribution system. The replacement of approximately 5,000 feet of water main (from Reed Street to Meadow Street) will provide improved fire flows in the area, increased resiliency by improving the hydraulic connection of the overall system, and improve the system's overall age. Estimated design cost is \$235,700 and cost of construction is \$2,357,000.



WATER MAIN REPLACEMENT – SOUTH STREET

The water main replacement for South Street was identified by Tighe & Bond using a hydraulic model of the city's water distribution system. The replacement of approximately 5,420 feet of water main will provide improved fire flows in the area, increased resiliency by improving the hydraulic connection of the water mains on Main and Suffield Streets, and improve the system's overall age. Estimated design cost is \$262,500.00 and estimated cost of construction is \$2,625,000.



Capital Improvement
Program
FY2027 – FY2031

PROJECT DESCRIPTIONS

ENTERPRISE FUNDS

29

WATER MAIN REPLACEMENT – BELVIDERE & BROOKLINE

The water main replacement for Brookline and Belvidere Streets. This neighborhood has a history of water main breaks and the city has applied for State Revolving Fund (SRF) loan for the estimated project construction costs but these funds cannot be used for design. This project is in addition to the sewer lining and drainage replacement proposed under a separate SRF application. The replacement of approximately 2,400 feet of undersized water main will provide improved fire flows in the area, add resiliency to the water system, and improve the overall age of the water system. Estimated design cost is \$141,750 and estimated cost of construction is \$1,417,500.

WATER MAIN REPLACEMENT – SUFFIELD STREET

The water main replacement for Suffield Street was identified by Tighe & Bond using a hydraulic model of the city's water distribution system. The replacement of approximately 4,176 feet of water main (from Route 57 overpass to Silver Street) will provide improved fire flows in the area, increased resiliency by improving the hydraulic connection of the overall system, and improve the system's overall age. Estimated design cost is \$189,000 and estimated cost of construction is \$1,890,000.

WATER MAIN REPLACEMENT – SILVER STREET, PERRY LANE & MILL STREET

The water main replacement for Silver Street, Perry Lane and Mill Street was identified by Tighe & Bond using a hydraulic model of the city's water distribution system. The replacement of approximately 3,478 feet of water main (from Suffield Street looping back to Mill Street via Silver Street/Perry Lane) will provide improved fire flows in the area, increased resiliency by improving the hydraulic connection of the overall system, and improve the system's overall age. Estimated design cost is \$157,500 and estimated cost of construction is \$1,575,000.



Capital Improvement
Program
FY2027 – FY2031

**PROJECT
DESCRIPTIONS**
ENTERPRISE FUNDS

30

WATER MAIN REPLACEMENT – RIVER ROAD

The water main replacement for River Road was identified by Tighe & Bond using a hydraulic model of the city's water distribution system. The replacement of approximately 15,000 feet of water main (from Main Street to the Route 57 rotary) will provide improved fire flows in the area, increased resiliency by improving the hydraulic connection of the overall system, and improve the system's overall age. Estimated design cost is \$420,000 and estimated cost of construction is \$4,200,000.



AGAWAM MUNICIPAL GOLF COURSE

GOLF COURSE EQUIPMENT

An annual capital appropriation is included to provide for the ongoing replacement of equipment on a scheduled maintenance program. Funds may be carried from one fiscal year to the next in order to provide funding for high value, large Municipal Golf Course capital equipment.



Capital Improvement
Program
FY2027 – FY2031

CAPITAL
IMPROVEMENT
APPROPRIATIONS
FY2027

31

<u>GENERAL FUND APPROPRIATIONS</u>		Amount
Description		
Department of Public Works Equipment		\$580,000
Sidewalk Rehabilitation and Extension		\$250,000
Street/Infrastructure Improvement Program		\$600,000
Traffic Light Improvements		\$40,000
Junior High School Floor		\$135,000
Fire Department Equipment (including new fire boat)		\$182,000
Building Maintenance Equipment		\$35,000
IT Network Infrastructure Modernization		\$200,000
Fire HQ Generator		\$55,000
Total		\$2,077,000
<u>WASTEWATER ENTERPRISE FUND APPROPRIATIONS</u>		Amount
Description		
Wastewater Equipment Replacement		\$47,174
Sewer System Infiltration Survey		\$218,350
Total		\$265,524
<u>WATER ENTERPRISE FUND APPROPRIATIONS</u>		Amount
Description		
Water Equipment Replacement		\$47,174
Water Meter Replacement		\$350,000
Total		\$397,174
<u>GOLF ENTERPRISE FUND APPROPRIATIONS</u>		Amount
Description		
Municipal Golf Course Equipment Replacement		\$25,000
Total		\$25,000



Capital Improvement
Program
FY2027 – FY2031

CAPITAL
IMPROVEMENT
APPROPRIATIONS
FY2028

32

<u>GENERAL FUND APPROPRIATIONS</u>		Amount
Description		
Department of Public Works Equipment		\$500,000
Sidewalk Rehabilitation and Extension		\$250,000
Street/Infrastructure Improvement Program		\$600,000
Traffic Light Improvements		\$40,000
Feasibility Study – Recreation Center at Perry Lane Park		\$125,000
Fire Department Dispatch Operations Improvements		\$225,000
Fire Headquarters Roof and HVAC		\$405,000
New Telephone System		\$75,000
Fire Department Equipment		\$100,000
Building Maintenance Equipment		\$35,000
Total		\$2,355,000
<u>WASTEWATER ENTERPRISE FUND APPROPRIATIONS</u>		Amount
Description		
Wastewater Equipment Replacement		\$47,174
Design Work for Sewer Replacement		\$100,000
Total		\$147,174
<u>WATER ENTERPRISE FUND APPROPRIATIONS</u>		Amount
Description		
Water Equipment Replacement		\$47,174
Water Meter Replacement		\$350,000
Total		\$397,174
<u>GOLF ENTERPRISE FUND APPROPRIATIONS</u>		Amount
	Description	
	Municipal Golf Course Equipment Replacement	\$25,000
Total		\$25,000



Capital Improvement
Program
FY2027 – FY2031

**CAPITAL
IMPROVEMENT
APPROPRIATIONS
FY2029**

33

<u>GENERAL FUND APPROPRIATIONS</u>		Amount
Description		
Department of Public Works Equipment		\$500,000
Sidewalk Rehabilitation and Extension		\$250,000
Street/Infrastructure Improvement Program		\$600,000
Traffic Light Improvements		\$40,000
DPW Boiler Replacement		\$180,000
Town Hall HVAC Automation		\$30,000
Fire Department Furniture & Equipment		\$155,000
Fire Station Paving		\$225,000
Building Maintenance Equipment		\$35,000
Total		\$2,015,000
<u>WASTEWATER ENTERPRISE FUND APPROPRIATIONS</u>		Amount
Description		
Wastewater Equipment Replacement		\$47,174
Design Work for Sewer Replacement		\$100,000
Total		\$147,174
<u>WATER ENTERPRISE FUND APPROPRIATIONS</u>		Amount
Description		
Water Equipment Replacement		\$47,174
Water Meter Replacement		\$350,000
Total		\$397,174
<u>GOLF ENTERPRISE FUND APPROPRIATIONS</u>		Amount
Description		
Municipal Golf Course Equipment Replacement		\$25,000
Total		\$25,000



Capital Improvement
Program
FY2027 – FY2031

CAPITAL IMPROVEMENT APPROPRIATIONS FY2030

34

<u>GENERAL FUND APPROPRIATIONS</u>	
Description	Amount
Department of Public Works Equipment	\$500,000
Sidewalk Rehabilitation and Extension	\$250,000
Street/Infrastructure Improvement Program	\$600,000
Traffic Light Improvements	\$40,000
Doering School Flooring	\$235,000
Fire Department Equipment	\$100,000
Building Maintenance Equipment	\$35,000
Fire Department Radio Replacement	\$500,000
Total	\$2,260,000
<u>WASTEWATER ENTERPRISE FUND APPROPRIATIONS</u>	
Description	Amount
Wastewater Equipment Replacement	\$47,174
Design Work for Sewer Replacement	\$100,000
Total	\$147,174
<u>WATER ENTERPRISE FUND APPROPRIATIONS</u>	
Description	Amount
Water Equipment Replacement	\$47,174
Water Meter Replacement	\$350,000
Total	\$397,174
<u>GOLF ENTERPRISE FUND APPROPRIATIONS</u>	
Description	Amount
Municipal Golf Course Equipment Replacement	\$25,000
Total	\$25,000



Capital Improvement
Program
FY2027 – FY2031

CAPITAL
IMPROVEMENT
APPROPRIATIONS
FY2031

35

<u>GENERAL FUND APPROPRIATIONS</u>		Amount
Description		
Department of Public Works Equipment		\$500,000
Sidewalk Rehabilitation and Extension		\$250,000
Street/Infrastructure Improvement Program		\$600,000
Traffic Light Improvements		\$40,000
Fire Department Overhead Doors		\$180,000
Fire Department Radio Antenna		\$600,000
Fire Department Equipment		\$100,000
Building Maintenance Equipment		\$35,000
Total		\$2,305,000
<u>WASTEWATER ENTERPRISE FUND APPROPRIATIONS</u>		Amount
Description		
Wastewater Equipment Replacement		\$47,174
Design Work for Sewer Replacement		\$100,000
Total		\$147,174
<u>WATER ENTERPRISE FUND APPROPRIATIONS</u>		Amount
Description		
Water Equipment Replacement		\$47,174
Water Meter Replacement		\$300,000
Total		\$347,174
<u>GOLF ENTERPRISE FUND APPROPRIATIONS</u>		Amount
Description		
Municipal Golf Course Equipment Replacement		\$25,000
Total		\$25,000



Capital Improvement
Program
FY2027 – FY2031

CAPITAL
IMPROVEMENTS
NEW BONDS

36

Project Description and Anticipated 1 st Year Bond Payment	Amount	Projected 1 st Year Bond Payment
NEW GENERAL FUND PROJECTS		
Elementary School Roofs (FY2029)	\$5,450,000	\$252,063
Fire Engines (FY2029)	\$2,577,398	\$367,279
Agawam High School Project (FY2030)	\$129,427,167	\$9,814,893
DPW Building Roof Replacement (FY2030)	\$1,850,000	\$201,958
Doering School Roof Replacement (FY2030)	\$1,850,000	\$201,958
WATER FUND PROJECTS		
Main Street Water Main Replacement (FY2028)	\$2,357,000	\$218,023
South Street Water Main Replacement (FY2029)	\$2,625,000	\$242,813
Suffield Street Water Main Replacement (FY2030)	\$1,890,000	\$174,825
Belvidere/Brookline Water Main Replacement (FY2030)	\$1,417,500	\$131,119
Silver/Perry/Mill Water Main Replacement (FY2031)	\$1,575,000	\$145,688
Vacuum/Jet Truck (FY2031)	\$325,000	\$46,313
River Road Water Main Replacement (FY2031)	\$4,200,000	\$388,500
WASTEWATER FUND PROJECTS		
Reed Street Outfall Project (FY2027)	\$691,600	\$98,553
Main Street Sewer Rehabilitation (FY2028)	\$1,500,000	\$138,750
School Street Odor Control (FY2029)	\$2,310,000	\$213,675
Vacuum/Jet Truck (FY2031)	\$325,000	\$46,313
(*all projected bond payments are based on an annual bond interest rate of 4.25%)		



Capital Improvement
Program
FY2027 – FY2031

**ANNUAL
APPROPRIATIONS**
FY2027 TO FY2031

37

	FY2027	FY2028	FY2029	FY2030	FY2031
GENERAL FUND APPROPRIATIONS	\$2,077,000	\$2,355,000	\$2,015,000	\$2,260,000	\$2,305,000
WATER FUND APPROPRIATIONS	\$397,174	\$397,174	\$397,174	\$397,174	\$397,174
WASTEWATER FUND APPROPRIATIONS	\$265,524	\$147,174	\$147,174	\$147,174	\$147,174
GOLF FUND APPROPRIATIONS	\$25,000	\$25,000	\$25,000	\$25,000	\$25,000
TOTAL ANNUAL APPROPRIATIONS	\$2,764,698	\$2,924,348	\$2,584,348	\$2,829,348	\$2,874,348



Capital Improvement
Program
FY2027 – FY2031

ANNUAL
APPROPRIATIONS
FY2027 TO FY2031

38

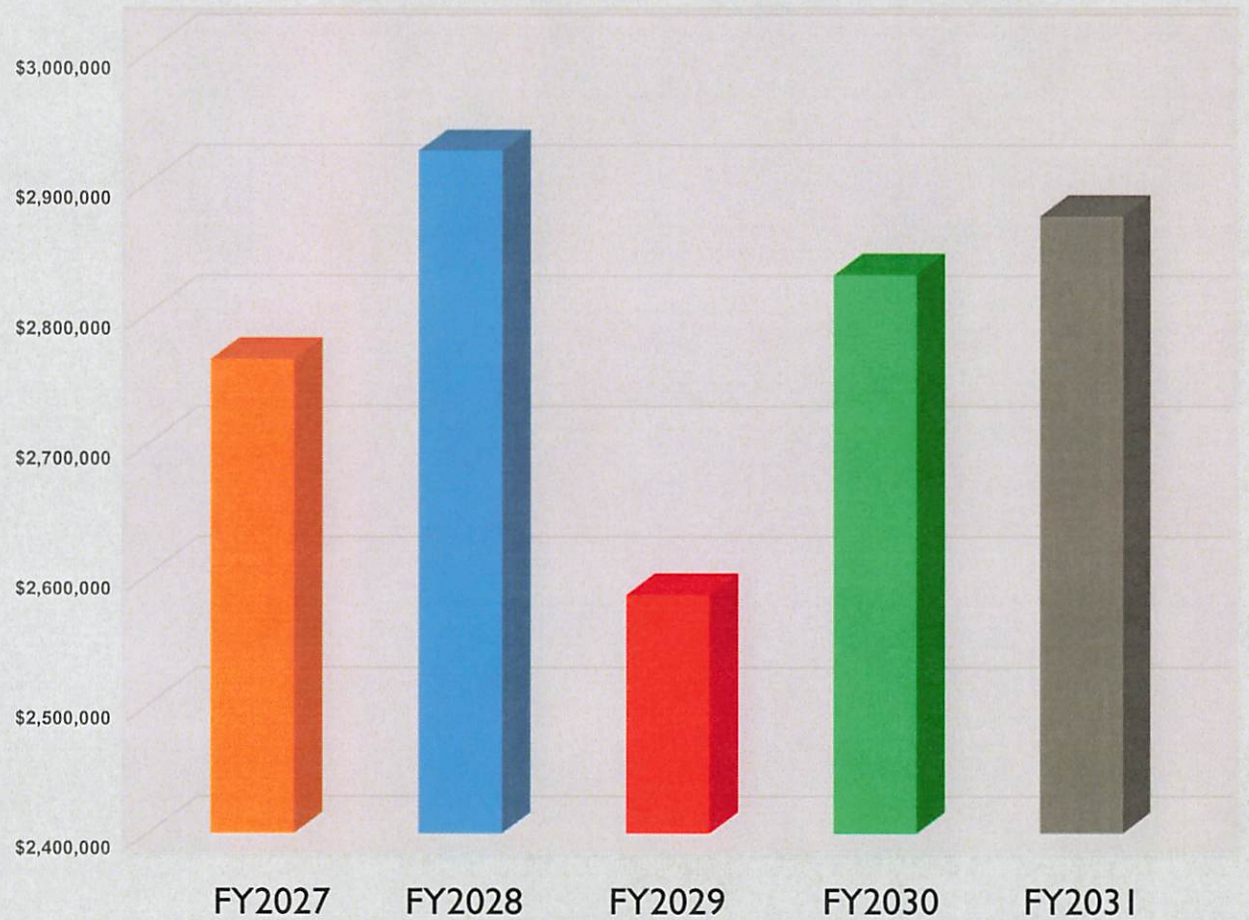



Capital Improvement
Program
FY2027 – FY2031

**GENERAL FUND
EXISTING BOND
COSTS**
(FY2027 – FY2031)

39

	FY2027	FY2028	FY2029	FY2030	FY2031
Senior Center	\$357,361	\$342,454			
Building Maintenance Ext	\$5,725	\$5,600	\$5,450	\$5,300	\$5,150
Athletic Facilities	\$570,470	\$560,370	\$545,270	\$535,270	\$525,270
Middle School Boiler	\$37,800	\$36,400			
DPW Façade Repair	\$17,280	\$16,640			
Middle School Stormwater	\$124,250	\$114,000	\$109,000	\$104,000	\$102,000
Jr High Boiler	\$35,250	\$33,750	\$27,250	\$26,000	\$25,500
LED Streetlights	\$142,600	\$136,600	\$130,600	\$119,600	\$117,300
Police Station/Still Brook/Library	\$1,897,969	\$1,845,219	\$1,782,719	\$1,730,469	\$1,678,219
Existing General Fund Bond Costs	\$3,188,705	\$3,091,033	\$2,600,289	\$2,520,639	\$2,453,439

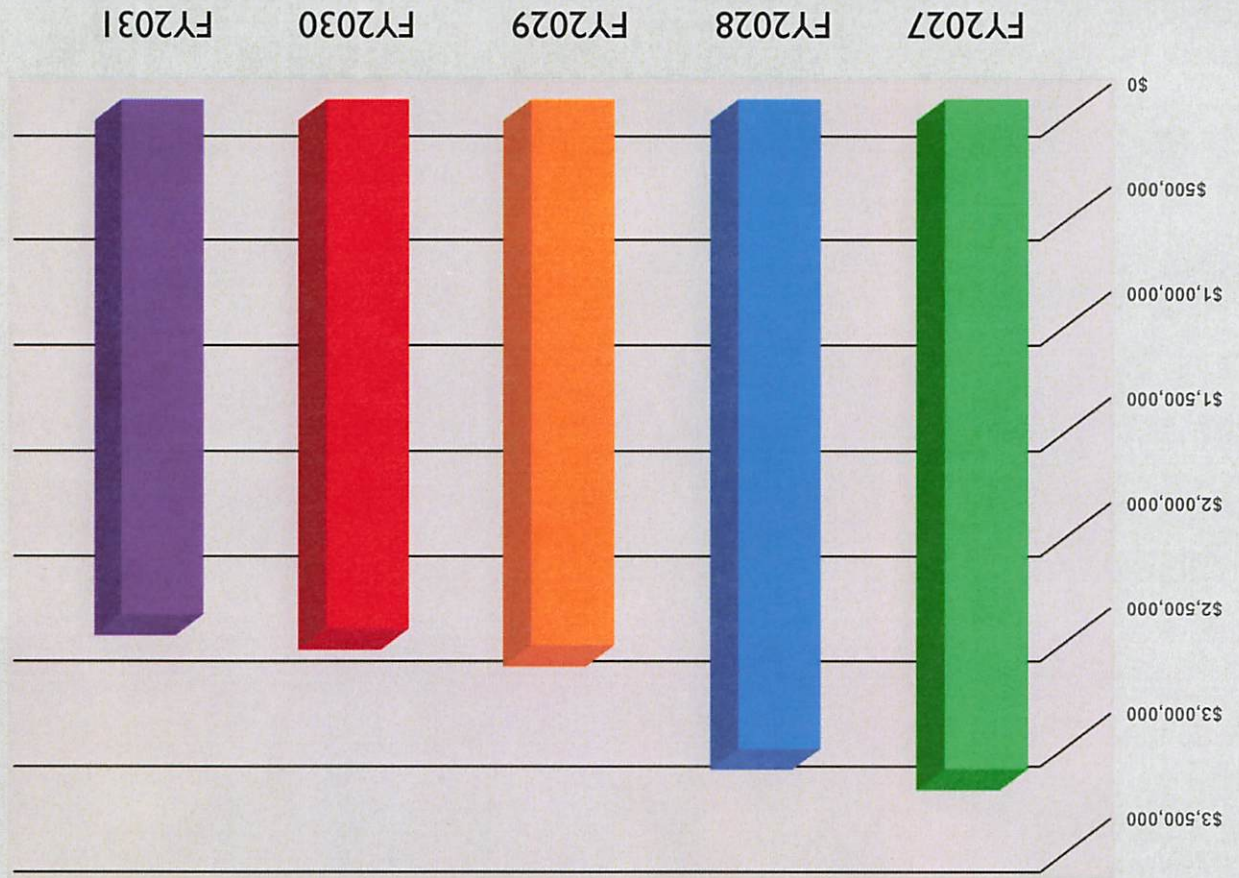

40

(FY2027 - FY2031)

EXISTING BOND COSTS

GENERAL FUND



Capital Improvement Program
FY2027 - FY2031



Capital Improvement
Program
FY2027 – FY2031

GENERAL FUND
EXISTING AND NEW
BOND COSTS
(FY2027 – FY2031)

41

PROJECT	FY2027	FY2028	FY2029	FY2030	FY2031
Senior Center	\$357,361	\$342,454			
Building Maintenance Extension	\$5,725	\$5,600	\$5,450	\$5,300	\$5,150
Athletic Facilities	\$570,470	\$560,370	\$545,270	\$535,270	\$525,270
Middle School Boiler	\$37,800	\$36,400			
DPW Façade Repair	\$17,280	\$16,640			
Middle School Sewer/Stormwater	\$124,250	\$114,000	\$109,000	\$104,000	\$102,000
Jr High Boiler	\$35,250	\$33,750	\$27,250	\$26,000	\$25,500
LED Streetlights	\$142,600	\$136,600	\$130,600	\$119,600	\$117,300
Police Station/Still Brook/Library	\$1,897,969	\$1,845,219	\$1,782,719	\$1,730,469	\$1,678,219
Existing General Fund Bond Costs	\$3,188,705	\$3,091,033	\$2,600,289	\$2,520,639	\$2,453,439
Elementary School Roofs			\$252,063	\$246,272	\$240,481
Fire Engines			\$367,279	\$356,325	\$345,371
DPW Building Roof				\$201,958	\$196,717
Doering School Roof				\$201,958	\$196,717
Agawam High School Project				\$9,814,893	\$9,631,538
Projected New Bond Costs	\$0	\$0	\$619,342	\$10,821,406	\$10,610,824
Total Existing and New Bond Costs	\$3,188,705	\$3,091,033	\$3,219,631	\$13,342,045	\$13,064,263

42
 BOND COSTS
 (FY2027 - FY2031)
 EXISTING AND NEW
 GENERAL FUND

Capital Improvement
 Program
 FY2027 - FY2031

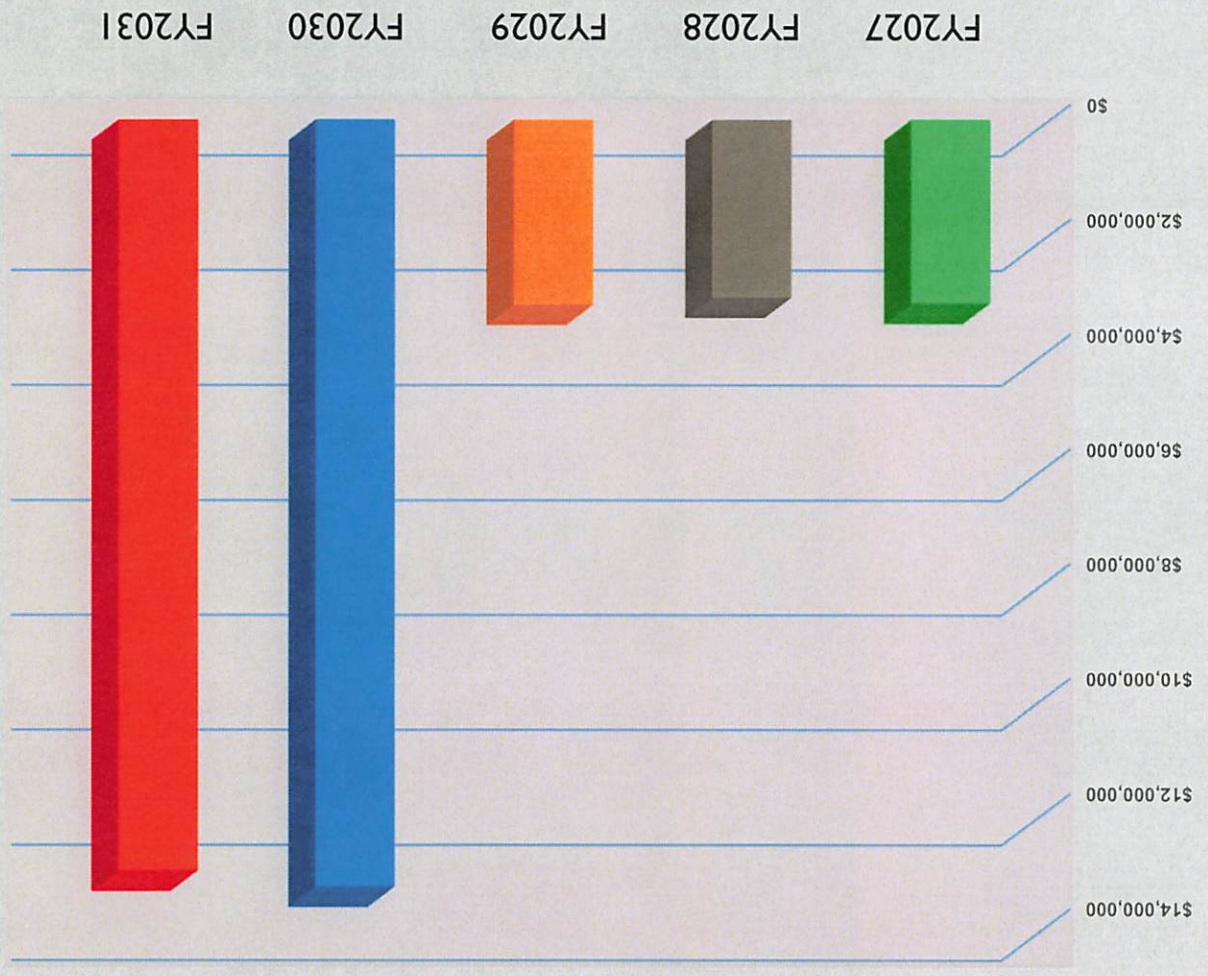

Capital Improvement
Program
FY2027 – FY2031

**SELF SUSTAINING
DEPARTMENTS
EXISTING BOND
COSTS**
(FY2027 – FY2031)

43

PROJECT	FY2027	FY2028	FY2029	FY2030	FY2031
WATER FUND					
No Westfield St Water Main	\$374,700	\$365,700	\$356,700	\$347,700	\$338,700
DPW Façade Repair	\$12,960	\$12,480			
Existing Water Bond Costs	\$387,660	\$378,180	\$356,700	\$347,700	\$338,700
WASTEWATER FUND					
Westfield River Force Main	\$40,626	\$40,626	\$40,626		
Feeding Hills Center Sewer	\$166,025	\$162,400	\$158,050	\$153,700	\$149,350
Storage Tanks	\$27,000	\$26,000			
DPW Façade Repair	\$12,960	\$12,480			
Existing Wastewater Bond Costs	\$246,611	\$241,506	\$198,676	\$153,700	\$149,350
Total Self Sustaining Bond Costs	\$634,271	\$619,686	\$555,376	\$501,400	\$488,050



Capital Improvement
Program
FY2027 – FY2031

SELF SUSTAINING
DEPARTMENTS
EXISTING BOND
COSTS
(FY2027 – FY2031)

44

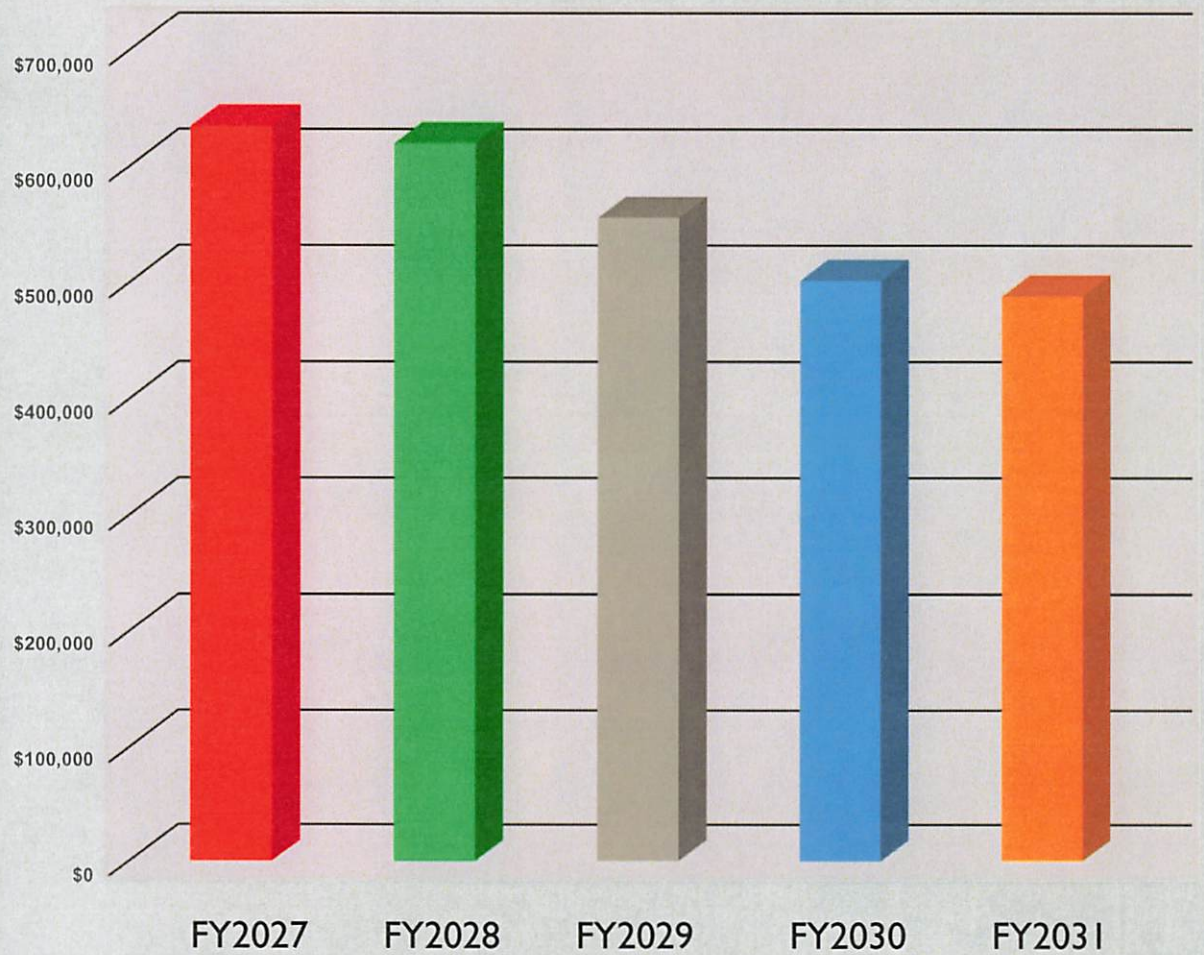



Capital Improvement
Program
FY2027 – FY2031

SELF SUSTAINING
DEPARTMENTS
EXISTING AND NEW
BOND COSTS
(FY2027 - FY2031)

45

EXISTING WATER PROJECTS	FY2027	FY2028	FY2029	FY2030	FY2031
North Westfield Street Water Main	\$374,700	\$365,700	\$356,700	\$347,700	\$338,700
DPW Façade Repair	\$12,960	\$12,480			
Existing Water Bond Costs	\$387,660	\$378,180	\$356,700	\$347,700	\$338,700
PROPOSED WATER PROJECTS					
Main Street Water Main		\$218,023	\$213,014	\$208,005	\$202,997
South Street Water Main			\$242,813	\$237,234	\$231,656
Suffield Street Water Main				\$174,825	\$170,809
Belvidere/Brookline Water Main				\$131,119	\$128,107
Jet/Vac Truck				\$46,313	\$44,931
Silver/Perry/Mill Street Water Main					\$145,688
River Road Water Main					\$388,500
Proposed Water Bond Costs	\$0	\$218,023	\$455,827	\$797,496	\$1,312,688
EXISTING WASTEWATER PROJECTS					
Westfield River Force Main	\$40,626	\$40,626	\$40,626		
Feeding Hills Center Sewer	\$166,025	\$162,400	\$158,050	\$153,700	\$149,350
Storage Tanks	\$27,000	\$26,000			
DPW Façade Repair	\$12,960	\$12,480			
Existing Wastewater Bond Costs	\$246,611	\$241,506	\$198,676	\$153,700	\$149,350
PROPOSED WASTEWATER PROJECTS					
Main Street Sewer		\$138,750	\$135,563	\$132,375	\$129,188
Reed Street Outfall Project		\$98,553	\$95,614	\$92,674	\$89,735
School Street Odor Control			\$213,675	\$208,766	\$203,858
Jet/Vac Truck				\$46,313	\$44,931
Proposed Wastewater Bond Costs	\$0	\$237,303	\$444,852	\$480,128	\$467,712
Total Existing Bond Costs	\$634,271	\$619,686	\$555,376	\$501,400	\$488,050
Total Existing and Proposed Bond Costs	\$634,271	\$1,075,012	\$1,456,055	\$1,779,024	\$2,268,450



Capital Improvement
Program
FY2027 – FY2031

SELF SUSTAINING
DEPARTMENTS
EXISTING AND NEW
BOND COSTS
(FY2027 - FY2031)

46

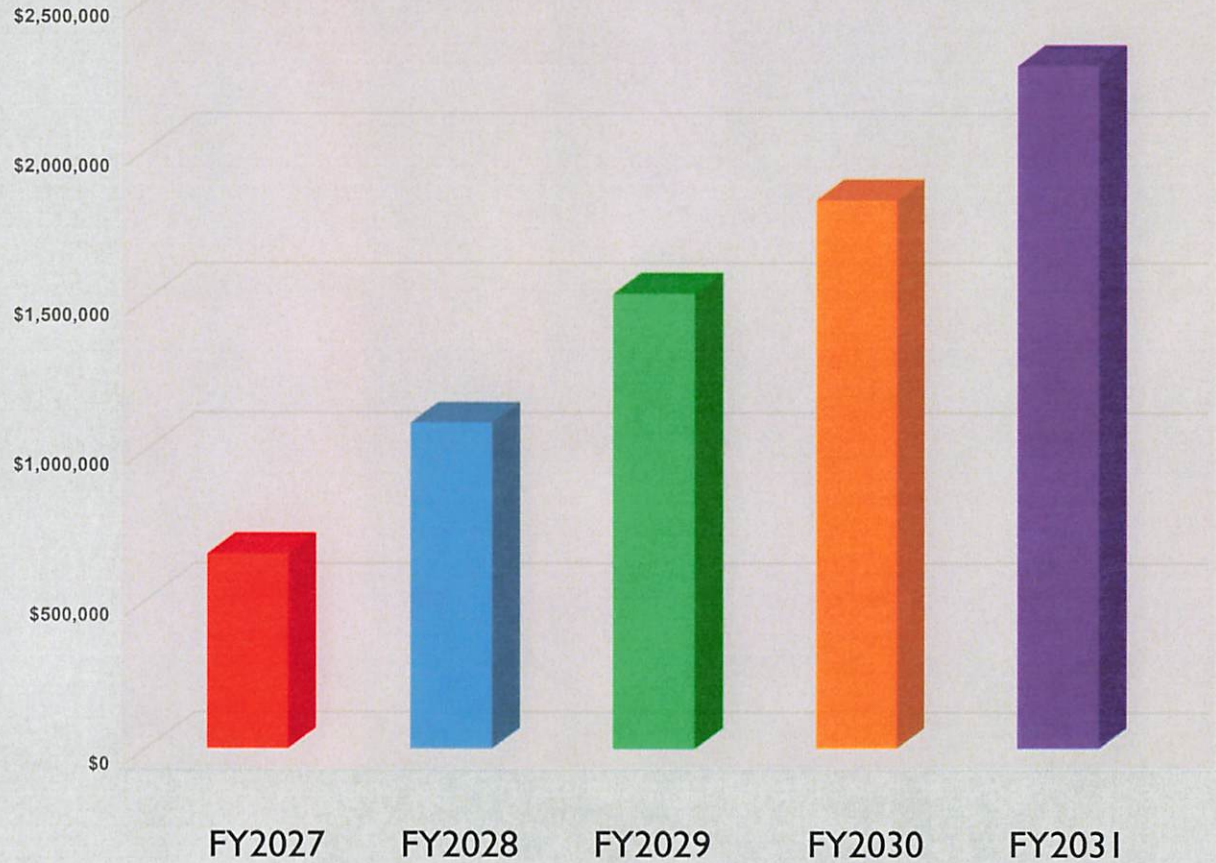



Capital Improvement
Program
FY2027 – FY2031

USEFUL LIFE
TOWN & SCHOOL
BUILDINGS

47

Buidling Component	Agawam Junior High	Doering Midde School
Roof	LT	MT
Boilers	LT	LT
Unit Vents/Air Handling Equipment	ST	MT
Electrical/Plumbing Systems	LT	LT
Flooring - Hallways	ST	ST
Flooring - Classrooms	LT	LT
Windows/Doors	LT	MT
Lighting	MT	MT
Generator	LT	MT
Elevator	MT	MT
Buidling Component	Clark School	Granger School
Roof	ST	ST
Boilers	MT	LT
Unit Vents/Air Handling Equipment	MT	MT
Electrical/Plumbing Systems	LT	LT
Flooring - Hallways	MT	MT
Flooring - Classrooms	LT	LT
Windows/Doors	MT	MT
Lighting	MT	MT
Elevator	n/a	MT

Useful Life: ST = 5 to 10 years | MT = 10 to 20 years | LT = 20 + years



Capital Improvement
Program
FY2027 – FY2031

USEFUL LIFE
TOWN & SCHOOL
BUILDINGS
(CONTINUED)

48

Buidling Component	Phelps School	Sapelli School
Roof	ST	ST
Boilers	MT	ST
Unit Vents/Air Handling Equipment	MT	MT
Electrical/Plumbing Systems	LT	LT
Flooring - Hallways	MT	MT
Flooring - Classrooms	LT	LT
Windows/Doors	MT	MT
Lighting	ST	ST
Elevator	MT	n/a
Buidling Component	Building Maint	DPW
Roof	LT	ST
Boilers	LT	ST
Unit Vents/Air Handling Equipment	MT	MT
Electrical/Plumbing Systems	LT	LT
Flooring	LT	ST
Windows/Doors	LT	MT
Lighting	MT	MT

Useful Life: ST = 5 to 10 years | MT = 10 to 20 years | LT = 20 + years



Capital Improvement
Program
FY2027 – FY2031

USEFUL LIFE
TOWN & SCHOOL
BUILDINGS
(CONTINUED)

49

Buidling Component	Fire HQ	Fire Station 2
Roof	ST	ST
Boilers	MT	ST
Unit Vents/Air Handling Equipment	MT	n/a
Electrical/Plumbing Systems	LT	LT
Flooring	MT	MT
Windows/Doors	MT	MT
Lighting	MT	MT
Buidling Component	Senior Center	Library
Roof	MT	LT
Boilers	LT	LT
Unit Vents/Air Handling Equipment	MT	MT
Electrical/Plumbing Systems	LT	LT
Flooring	LT	LT
Windows/Doors	MT	MT
Lighting	LT	LT
Elevator	LT	LT

Useful Life: ST = 5 to 10 years | MT = 10 to 20 years | LT = 20 + years



Capital Improvement
Program
FY2027 – FY2031

USEFUL LIFE
TOWN & SCHOOL
BUILDINGS
(CONTINUED)

50

Buidling Component	Town Hall	Golf Clubhouse
Roof	LT	LT
Boilers	LT	LT
Unit Vents/Air Handling Equipment	LT	n/a
Electrical/Plumbing Systems	LT	LT
Flooring	MT	MT
Windows/Doors	ST	LT
Lighting	ST	MT

Useful Life: ST = 5 to 10 years | MT = 10 to 20 years | LT = 20 + years

THANK YOU

**TO THE CAPITAL IMPROVEMENT TEAM
BRIAN PAGELLA, MARIO MAZZA, ALAN SIROIS
& NADINE PORFILIO**

**CHRISTOPHER C. JOHNSON
MAYOR**

**PETITION FOR ZONE CHANGE BY CHARLIE’S GARDEN PARK, L.L.C. FOR
PROPERTY LOCATED AT 1399 SUFFIELD STREET, AGAWAM, HAMPDEN
COUNTY, MASSACHUSETTS (ASSESSOR PARCEL I3-2-7) AND
PROPERTY KNOWN AS PARCEL 2 SUFFIELD STREET, AGAWAM, HAMPDEN
COUNTY, MASSACHUSETTS (ASSESSOR PARCEL I3-2-31)**

WHEREAS, Charlie’s Garden Park, L.L.C. (the “Petitioner”) is the owner of a parcel of land located at 1399 Suffield Street, Agawam, Hampden County, Massachusetts (Assessor Parcel I3-2-7) and Parcel 2 Suffield Street, Agawam, Hampden County, Massachusetts (Assessor Parcel I3-2-3) which are more particularly described in a deed which is recorded in the Hampden County Registry of Deeds in Book 25589, Page 309; and

WHEREAS, Charlie’s Garden Park, L.L.C. has submitted a Petition dated March 23, 2026 seeking to add a portion of the Assessors Parcels described above to the Agawam Mixed-Use Business C District and to change the zoning on the balance of the Parcels from the Business A District to the Agricultural District; and

WHEREAS, the Petitioner indicates in its Petition that “[*t*]he proposed zoning amendment is intended to allow for mixed light commercial and residential development on the site appropriate to the neighborhood... [*and it*]... would support mixed-uses on the subject property that aligns with the transition from commercial to residential...”; and

WHEREAS, the Petitioner further indicates in its Petition that the zone change “*will be desirable and without substantial detriment to the public good*”; and

NOW THEREFORE, the Agawam City Council hereby resolves as follows:

1. to amend Article XIX of the Code of the Town of Agawam entitled “Mixed-Use Business C District” by amending Paragraph A of §180-141 to add the following to the list of properties contained therein: “that portion of Assessors Parcels I3-2-7 and I3-2-31 which is designated as “PROPOSED ZONE MIXED-USE BUSINESS C OVERLAY DISTRICT” on the plan entitled “PLAN FOR ZONING MAP AMENDMENT 1399 Suffield Street & Par 2 Suffield Street Agawam, Massachusetts Parcel IDs: I3-2-7 & I3-2-31” dated March 17, 2026 by R. Levesque Associates” - a copy of said plan is attached hereto and incorporated herein by reference; and
2. to change the zoning of that portion of Assessors Parcels I3-2-7 and I3-2-31 which is designated as “PROPOSED ZONE AGRICULTURE” on the plan entitled “PLAN FOR ZONING MAP AMENDMENT 1399 Suffield Street & Par 2 Suffield Street Agawam, Massachusetts Parcel IDs: I3-2-7 & I3-2-31” dated March 17, 2026 by R. Levesque Associates” from the Business A District to the Agricultural District - a copy of said plan is attached hereto and incorporated herein by reference.

Dated this _____ day of _____, 2026.

PER ORDER OF THE AGAWAM CITY COUNCIL

Anthony J. Russo, President

APPROVED AS TO FORM AND LEGALITY



Christopher S. Cappucci, Solicitor





NOTES

1. THE RECORD OWNER OF THE SUBJECT PARCELS IS CHARLIE'S GARDEN PARK L.L.C. SEE HAMPDEN COUNTY REGISTRY OF DEEDS BOOK 25589 PAGE 309.
2. THE PROPERTY LINES SHOWN HEREON ARE BASED UPON PLAN RECORDED IN HAMPDEN COUNTY REGISTRY OF DEEDS BOOK OF PLANS 281 PAGE 53.
3. THIS PLAN HAS BEEN PREPARED FOR SITE PLANNING PURPOSES AND SHALL NOT BE USED FOR THE CONVEYANCE OF LAND OR FOR ANY OTHER USE.
4. ADJACENT PROPERTY LINES AND ABUTTERS SHOWN HEREON ARE REFERENCED FROM MASS GIS AND ARE APPROXIMATE.

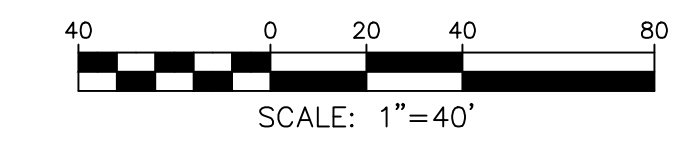
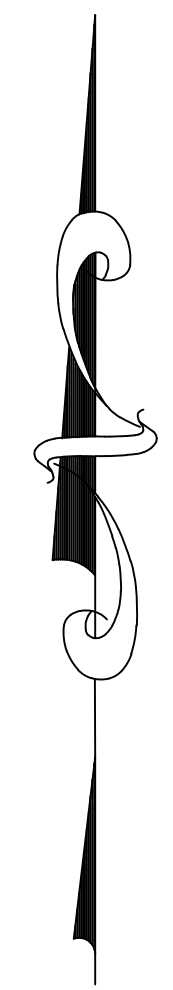

RLA
R LEVESQUE ASSOCIATES INC
 Landscape Architects
 Civil Engineers - Land Surveyors
 Environmental Consultants
 ph: 413.568.0985 fax: 413.568.0986
 40 School Street
 Westfield, MA 01085
 rlaland.com

PLAN FOR ZONING MAP AMENDMENT
1399 Suffield Street & Par 2 Suffield Street
Agawam, Massachusetts
Parcel IDs : 13-2-7 & 13-2-31

PREPARED FOR:
 Charlie's Garden Park, LLC
 c/o Clark Dore, Manager
 1775 Main Street
 Agawam, MA

ISSUANCE DATE:	3-17-2026
REVISIONS:	DATE:

DRAFTED BY: i.a.
 UNAUTHORIZED ALTERATION OF THIS DOCUMENT IS A VIOLATION OF MASSACHUSETTS STATE LAW

SCALE:	As Noted
RLA PROJ. NUMBER:	260116
DRAWING#	REV.
Z-1	-

Request for Zoning Map Amendment

Under Town of Agawam Zoning Ordinance Section 180-3 – Building Zone Map.

Proposed Underlying & Overlay District Zoning Map Amendment

Project Location:

1399 Suffield Street & Parcel 2 Suffield Street
Agawam, Massachusetts 01001
(Parcel IDs: I3-2-7 & I3-2-31)

Submitted To:

Town of Agawam City Council
36 Main Street
Agawam, Massachusetts 01001

Applicant & Property Owner:

Charlie's Garden Park, LLC
c/o Clark Dore, Manager
1775 Main Street
Agawam, Massachusetts 01001

RLA Project File No. 260116

March 23, 2026

R LEVESQUE ASSOCIATES, INC.

A LAND PLANNING SERVICES COMPANY

40 School Street, Westfield, MA 01085

p 413.568.0985 · f 413.568.0986 · www.rlaland.com



TABLE OF CONTENTS

SECTION

1. PETITION LETTER
2. LOCUS MAP
3. DEED REFERENCE

LIST OF APPENDICES

APPENDICES

- APPENDIX A: SITE PLAN
APPENDIX B: COLOR RENDERING

I. PETITION LETTER

R LEVESQUE ASSOCIATES, INC.

40 School Street, P.O. BOX 640, Westfield, MA 01085

p 413.568.0985 · f 413.568.0986 · www.rland.com



March 23, 2026

Anthony J. Russo, Council President
Town of Agawam City Council
36 Main Street
Agawam, Massachusetts 01001

**RE: Request for Zoning Map Amendment
1399 Suffield Street & Parcel 2 Suffield Street
Agawam, Massachusetts 01001
(Parcel IDs: I3-2-7 & I3-2-31)
RLA Project File No. 260116**

Dear President Russo and Councilors:

On behalf of the applicant and property owner, Charlie's Garden Park, LLC c/o Clark Dore, Manager, R Levesque Associates, Inc. is submitting this Request for Zoning Map Amendment for the above-referenced properties in Agawam, Massachusetts.

PROPERTY DESCRIPTION

The subject properties are located on the corner of Suffield Street and South Street and consist of approximately $6.28 \pm$ cumulative acres. The subject properties are owned by Charlie's Garden Park, LLC and are recorded under the Hampden County Registry of Deeds in Book 25589, Page 309. A copy of the deed reference is included within this petition packet under Section 3. According to the Town of Agawam Zoning Map, 1399 Suffield Street is split zoned between Business A and Residence A-2, and Parcel 2 Suffield Street is split zoned between Business A, Residence A-2, and Agricultural. A Locus Map depicting the properties' location and current zoning is included within this petition packet under Section 2.

ZONING MAP AMENDMENT PETITION

The petitioner respectfully requests that the Town of Agawam grant the above-referenced Zoning Map Amendment under the Massachusetts General Laws Chapter 40A Section 5 to amend the Town of Agawam Building Zone Map to allow for underlying zoning of Business A ($2.17 \pm$ acres) and Agricultural ($4.11 \pm$ acres), with the application of the Business C Mixed-Use Overlay District over the proposed Business A portion of the properties. Please see the accompanying filing plan for demarcation of the proposed zone lines.



STATEMENT OF PURPOSE

The proposed zoning amendment is intended to allow for mixed light commercial and residential development on the site appropriate to the neighborhood. The proposed application of the Mixed-Use Business C overlay would support mixed-uses on the subject property that aligns with the transition from commercial to residential.

STATEMENT OF JUSTIFICATION

Facts to support a finding that the proposed Zoning Map Amendment will be desirable and without substantial detriment to the public good:

1. Rezoning the property will create opportunities for residential and mixed-use development that can make efficient use of the site while supporting the availability of housing and neighborhood-serving uses.
2. The requested amendment will not result in a substantial detriment to the public good, as the surrounding area already contains residential neighborhoods and a mix of uses similar to those allowed within the Mixed-Use Business C overlay. The overlay is specifically designed to ensure that commercial and residential activities are compatible with one another and with surrounding properties.
3. The site contains sufficient area and configuration to accommodate residential or mixed-use development while providing appropriate circulation, open space, and site design elements consistent with the district's development standards.
4. The Mixed-Use Business C overlay encourages development that integrates residential uses with small-scale commercial or service uses in a manner that supports pedestrian activity, neighborhood services, and a high-quality built environment. Allowing this overlay at the subject properties will promote a more appropriate transition between residential areas and nearby commercial activity while supporting future development that is compatible with the surrounding neighborhood.
5. The underlying zoning of Business A, with Agricultural zoning along the north and east property lines, establishes a framework that preserves the existing development pattern and character of the area. The proposed Mixed-Use Business C overlay builds upon this foundation by allowing for context-sensitive infill and redevelopment, rather than introducing uses or intensities that would be inconsistent with the surrounding environment.

R LEVESQUE ASSOCIATES, INC.

40 School Street, P.O. BOX 640, Westfield, MA 01085

p 413.568.0985 · f 413.568.0986 · www.rland.com

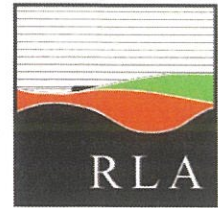

CONCLUSION

Understanding the above, the proposed Zoning Map Amendment is not detrimental to the public good and does not substantially derogate from the intent of and purpose of the Town of Agawam Zoning Ordinance. Based on the foregoing, and all the supplemental information attached, the applicant respectfully requests that the Town of Agawam City Council grant the requested Zoning Map Amendment under the Town of Agawam Zoning Ordinance.

Property Owner Signature: _____

Clark Dore, Manager on behalf of Charlie's Garden Park, LLC

As required, a copy of this submission has been provided electronically via email to the Town of Agawam City Council and Planning Board. We are requesting to be placed on the City Council's next available agenda. Should you have any questions or comments regarding this submission, please do not hesitate to contact our office at your earliest convenience.

Sincerely,

R LEVESQUE ASSOCIATES, INC.

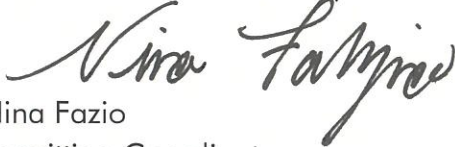

Nina Fazio

Permitting Coordinator

2. LOCUS MAP

(SOURCE: TOWN OF AGAWAM GIS)

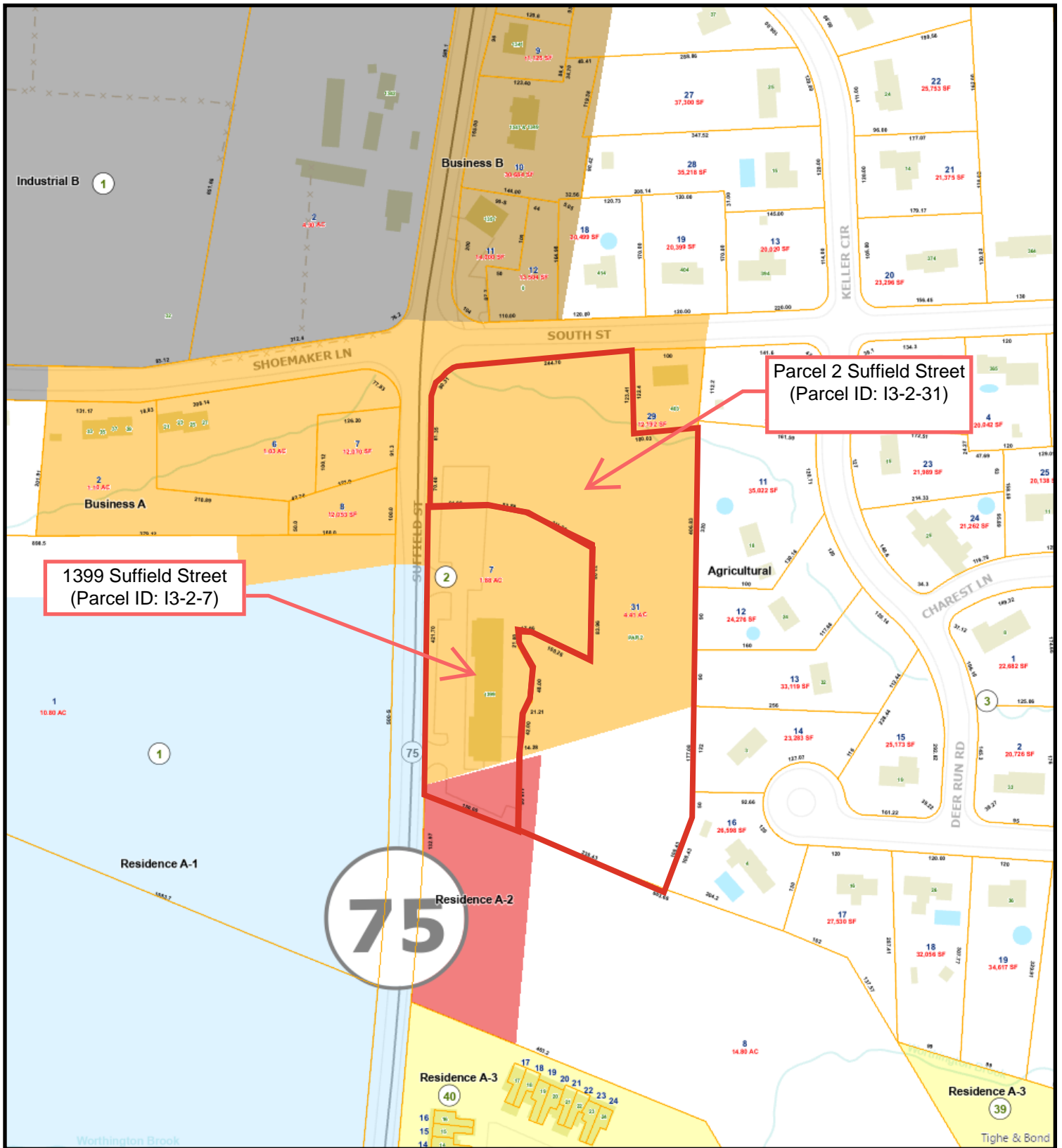

Locus Map

3/16/2026 9:32:33 AM

Scale: 1"=200'

Scale is approximate

The information depicted on this map is for planning purposes only. It is not adequate for legal boundary definition, regulatory interpretation, or parcel-level analyses.



3. DEED REFERENCE

(SOURCE: HAMPDEN COUNTY REGISTRY OF DEEDS)

AFFECTED PREMISES:
1399 Suffield Street
Agawam, Massachusetts

QUITCLAIM DEED

BRIARWOOD TWELVE, LLC, a Massachusetts limited liability company with an address of 1380 Main Street, Springfield, Massachusetts 01103

For consideration paid of **FIVE HUNDRED TWENTY-FIVE THOUSAND and 00/100 Dollars (\$525,000.00)**

grants **CHARLIE'S GARDEN PARK, L.L.C.**, a Massachusetts limited liability company of 1775 Main Street, Agawam, Massachusetts 01001

with **Quitclaim Covenants**

The land and buildings in Agawam, Hampden County, Massachusetts, bounded and described as follows:

Beginning at a point on the easterly line of Suffield Street said point being the point of intersection of the northerly boundary of land now or formerly of Western Massachusetts Electric Company and Suffield Street, thence

N. 15° 35' 16" E. along the easterly boundary of Suffield Street a distance of FIVE HUNDRED SEVENTY-THREE and 72/100ths (573.72) feet to a point; thence

NORTHEASTERLY along a curved line at the intersection of Suffield Street and South Street having a radius of SIXTY and 00/100ths (60.00) feet an arc distance of NINETY and 21/100ths (90.21) feet to a point on the southerly line of South Street; thence

S. 78° 23' 55" E. along the southerly boundary of South Street a distance of THREE HUNDRED FORTY-FOUR and 70/100ths (344.70) feet to a point; thence

S. 15° 40' 12" W. along the westerly boundary of land now or formerly of Bressett a distance of ONE HUNDRED TWELVE and 7/100ths (112.07) feet to a point; thence

S. 15° 38' 53" W. along land now or formerly of Hunters Greene, Inc. a distance of FIVE HUNDRED EIGHTY-SEVEN and 93/100ths (587.93) feet to a point;

S. 37° 20' 23" W. along the westerly boundary of Lot six (6) of Hunters Greene Estates as shown on a plan of land of Ralph DePalma and Joseph A. Pacella recorded herewith in Book of Plans 281, Page 53 ONE HUNDRED

Page 1 of 5

EIGHT and 43/100ths (108.43) feet to a point on the northerly boundary of land now or formerly of Western Massachusetts Electric Company; thence

N. 52° 39' 37" W. along the northerly boundary of land now or formerly of Western Massachusetts Electric Company a distance of THREE HUNDRED EIGHTY-SIX and 43/100 (386.43) feet to the point of beginning.

Together with a twenty (20) foot grading and landscaping easement along the easterly boundary of the premises to be conveyed across the westerly portion of Lots numbered one (1); two (2); three (3); four (4) and six (6) of Hunters Greene Estates as shown on a plan of land entitled "Definitive plan – Hunters Green Estates – Agawam, Massachusetts" drawn by Foresight Land Services, dated September 16, 1987 and recorded in the Hampden County Registry of Deeds in Book of Plans 256, Page 59.

Together with the utility easement for the benefit of the parcel conveyed more accurately bounded and described as follows:

Beginning at a point on the westerly end of Hunter's Greene Circle which point also marks a corner of Lot Number Six (6) and a corner of Lot Number Four (4) as shown on said plan; thence

N. 74° 21' 07" W. along the common boundary between said Lot Number Six (6) and Lot Number Four (4) a distance of NINETY-TWO and 66/100 (92.66) feet to a point in the easterly line of the benefited land now or formerly owned by Ralph DePalma and Joseph A. Pacella;

N. 15° 38' 53" E. along the easterly boundary of land now or formerly of DePalma and Pacella a distance of TWENTY and 00/100 (20.00) feet to a point; thence

S. 74° 21' 07" E. through Lot Number Four (4) a distance of ONE HUNDRED TWO and 88/100 (102.88) feet to a point in the westerly end of Hunter's Greene Circle; thence

SOUTHWESTERLY along westerly line of Hunter's Greene Circle by a curve to the left having a radius of SIXTY and 00/100 (60.00) feet; an arc distance of TWENTY-TWO and 46/100 (22.46) feet to the point of beginning.

Together with the utility easement for the benefit of the parcel conveyed more accurately bounded and described as follows:

Beginning at a point on the westerly end of Hunter's Green Circle which point also marks a corner of Lot Number Six (6) and a corner of Lot Number Four (4) as shown on said Plan; thence

- N. 74° 21' 07" W. along the common boundary between said Lot Number Six (6) and Lot Number Four (4) a distance of NINETY-TWO and 66/100 (92.66) feet to a point in the easterly line of land owned by Ralph DePalma and Joseph A Pacella; thence
- S. 15° 38' 53" E. along the land of DePalma/Pacella a distance of ten and 00/100 (10.00) feet to a point; thence
- S. 74° 21' 07" E. through Lot Number Six (6) a distance of NINETY and 64/100 (90.64) feet to a point in the westerly end of Hunter's Greene Circle; thence
- NORTHEASTERLY along westerly line of Hunter's Greene Circle by a curve to the right having a radius of SIXTY and 00/100 (60.00) feet, an arc distance of TEN and 21/100 (10.21) to the point of beginning.

Being the same premises conveyed to Briarwood Twelve, LLC by Foreclosure Deed of Hampden Bank dated March 15, 2010 and recorded with the Hampden County Registry of Deeds in Book 18217, Page 24.

Grantor hereby certifies that it is not classified for the current taxable year as a corporation for federal income tax purposes.

[Remainder of page intentionally left blank]

WITNESS the execution hereof under seal this 27 day of September, 2024.

BRIARWOOD TWELVE, LLC

By: Estate of Lester Seidman, Manager

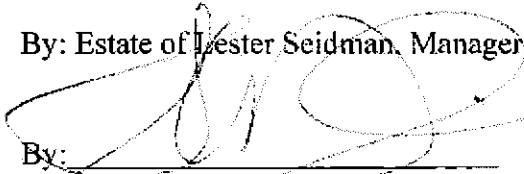

By:
Name: Susan A. McCoy,
Title: Co-Administrator

THE COMMONWEALTH OF MASSACHUSETTS

COUNTY OF HAMPDEN, ss

On this 27 day of September, 2024, before me, the undersigned notary public, personally appeared Susan A. McCoy, as Co-Administrator of the Estate of Lester Seidman, as Manager of Briarwood Twelve, LLC and proved to me through satisfactory evidence of identification, which was personal knowledge, to be the person whose name is signed on the preceding or attached document, and acknowledged to me that she signed it voluntarily for its stated purpose as Co-Administrator of the Estate of Lester Seidman as the voluntary act of the Estate as the Manager of Briarwood Twelve, LLC, a limited liability company as the voluntary act of the limited liability company.



Audrey L. Rome
My commission expires _____

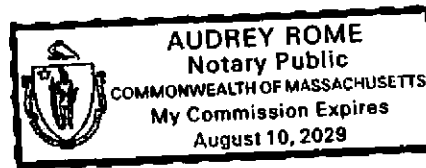

[Additional signature page below]

WITNESS the execution hereof under seal this 26th day of September, 2024.

BRIARWOOD TWELVE, LLC

By: The Estate of Lester Seidman

By: [Signature]
Name: Adam Lazaros
Title: Co-Administrator

STATE OF NEW JERSEY

COUNTY OF BERGEN

On this 26th day of September, 2024, before me, the undersigned notary public, personally appeared Adam Lazaros, as Co-Administrator of the Estate of Lester Seidman, as Manager of Briarwood Twelve LLC and proved to me through satisfactory evidence of identification, which was personal knowledge, to be the person whose name is signed on the preceding or attached document, and acknowledged to me that she signed it voluntarily for its stated purpose as Co-Administrator of the Estate of Lester Seidman as the voluntary act of the Estate as the Manager of Briarwood Twelve, LLC, a limited liability company as the voluntary act of the limited liability company.

[Signature]

[official signature and seal of notary]
My commission expires 01/27/2027

Morgan Shortell
Notary Public of New Jersey
Registration No. 50183818
Commission Expires 01/27/2027

APPENDIX A: SITE PLAN

SITE PLAN ENTITLED "PROPOSED ZONING MAP AMENDMENT"

PREPARED FOR CHARLIE'S GARDEN PARK, LLC

PREPARED BY R LEVESQUE ASSOCIATES, INC.

DATED MARCH 17, 2026

APPENDIX B: COLOR RENDERING

PREPARED BY R LEVESQUE ASSOCIATES, INC.



Town of Agawam

36 Main Street Agawam, Massachusetts 01001-1801

Tel. 413-786-0400

Fax 413-786-9927

Legal Notice

Town of Agawam

The **Agawam Planning Board** will hold a public hearing on Thursday, May 7, 2026 at 6:00pm and the **Agawam City Council** will hold a public hearing on Monday, May 18, 2026 at 7:00pm, both in the Veterans Hall at the Agawam Senior Center, 954 Main Street, Agawam, MA. The purpose of these hearings will be to hear the petition of Charlie's Garden Park for a zone change request for **1399 Suffield Street and Parcel 2 Suffield Street** from Business A, Agricultural, and Residence A-2 to just Business A and Agricultural and to include the parcels in the Mixed-Use Business C Overlay District. City Council's public hearing will be livestreamed on the Town of Agawam's website at www.agawam.ma.us and will also be televised on Cable Access Channel 15 or Channel 1074. Copies of the proposed zone change can be obtained from the Planning Department between the hours of 7:30am and 3:30pm at the Agawam DPW, 1000 Suffield Street, Agawam, MA or by emailing the Office of the City Clerk for an electronic copy at vgioscia@agawam.ma.us

By Order Of:

Violet Baldwin, Chair & Anthony Russo, President
Agawam Planning Board Agawam City Council

Advertise: Thursday, April 23, 2026 and Thursday, April 30, 2026

cc: Dept. of Housing & Community Development, Boston
Pioneer Valley Planning Commission
Planning Boards of:
 Longmeadow
 Southwick
 Springfield
 Suffield, CT
 West Springfield
 Westfield

BUDGETARY TRANSFER FORM

Department: Line Items

Amount: \$ 99,070.00 Date: April 2, 2026

From	<u>Line Items – Salary Reserve</u>	<u>16605 57350</u>
	Title of Account	Account Number

To	<u>Police Regular Permanent</u>	<u>\$ 82,288.00</u>	<u>12101 51010</u>
	Title of Account	Amount	Account Number
	<u>Police Overtime</u>	<u>\$ 10,000.00</u>	<u>12101 51030</u>
	Title of Account	Amount	Account Number
	<u>Police Holiday</u>	<u>\$ 6,782.00</u>	<u>12101 51050</u>
	Title of Account	Amount	Account Number

Reason for Transfer: To fund first year of new collective bargaining agreement with Agawam Police Patrolmen’s Association. See attached Settlement Agreement.



Christopher C. Johnson, Mayor

I hereby certify that funds are available to make the above-stated transfer.

Date: 04/02/2026 _____

Cheryl St. John, Auditor

I hereby approve placement of the above-stated transfer on the Council agenda.

Date: 04/02/2026 _____

Christopher C. Johnson, Mayor

Approved as to form and legality.

Date: 04/02/2026 _____

Christopher S. Cappucci, Solicitor

PER ORDER OF THE AGAWAM CITY COUNCIL – APPROVED ON _____, 20__

Date: _____

Anthony J. Russo, President

APPROVAL OF LEGISLATION: Pursuant to Section 3-6 of the Agawam Home Rule Charter, I hereby approve the Council passage of the above-stated transfer.

Date: _____

Christopher C. Johnson, Mayor

DISAPPROVAL OF LEGISLATION: Pursuant to Section 3-6 of the Agawam Home Rule Charter, I hereby disapprove the Council passage of the above-stated transfer.

Date: _____

Christopher C. Johnson, Mayor

**A RESOLUTION RELATIVE TO THE APPROVAL OF THE
WESTERN HAMPDEN DISTRICT VETERANS SERVICES INTER-
MUNICIPAL AGREEMENT BETWEEN THE CITY OF AGAWAM AND THE
TOWNS OF GRANVILLE, RUSSELL, SOUTHWICK, AND TOLLAND**

(Sponsored by Christopher C. Johnson, Mayor)

WHEREAS, the City of Agawam and the Towns of Granville, Russell, Southwick, and Tolland provide essential services to veterans of the armed forces of the United States of America; and

WHEREAS, these essential services include but are not limited to outreach services to veterans to educate them on benefits, offering referrals to programs and services for veterans and their dependents, facilitating financial benefits under Massachusetts General Laws Chapter 115, and helping veterans access employment assistance opportunities; and

WHEREAS, coordination with other municipalities saves the City of Agawam resources and facilitates better access to these essential services for veterans and their dependents; and

WHEREAS, an Inter-Municipal Agreement has been negotiated and prepared between the aforementioned municipalities to provide these essential services to veterans; and

WHEREAS, the approval of the Western Hampden District Veterans Services Inter-Municipal Agreement between the City of Agawam and the Towns of Granville, Russell, Southwick and Tolland is in the best interests of the town; and

NOW THEREFORE, the Agawam City Council hereby resolves to approve the Western Hampden District Veterans Services Inter-Municipal Agreement between the City of Agawam and the Towns of Granville, Russell, Southwick, and Tolland which is attached hereto and incorporated herein by reference.

Dated this _____ day of _____, 2026.

PER ORDER OF THE AGAWAM CITY COUNCIL

Anthony J. Russo, President

APPROVED AS TO FORM AND LEGALITY

Christopher S. Cappucci, Solicitor

**WESTERN HAMPDEN DISTRICT VETERANS SERVICES
INTER-MUNICIPAL AGREEMENT
BETWEEN THE CITY OF AGAWAM AND THE TOWNS OF
GRANVILLE, RUSSELL, SOUTHWICK AND TOLLAND**

This Agreement dated as of the ____ day of _____, 2026 (“Agreement”) by and between the City of Agawam (hereafter “Agawam” or “City”) and the Towns of Granville, Russell, Southwick and Tolland (hereafter collectively the “Towns”) is hereby entered into and is effective as of July 1, 2026, having been approved by the Mayor and City Council of Agawam and the Select Boards of the Towns. This Agreement enables the Western Hampden District Veterans Services Office (hereafter “Office”) and the staff of the Office to perform veterans’ services duties for the City and all of the Towns which are party to this Agreement. The term of this Agreement shall be for Fiscal Year 2027 (July 1, 2026 through June 30, 2027), and shall automatically renew annually unless any member community terminates the Agreement pursuant to Paragraph 13 below.

1. **District:** This Inter-Municipal Agreement shall govern the operation of the Western Hampden District Veterans Services Office which is located at the Agawam Senior Center at 954 Main Street, Agawam, MA 01001.
2. **Duties:** The Office shall deliver essential services to eligible veterans and their dependents, including but not limited to: outreach services to veterans to educate them on benefits and services; offering referrals to programs and services for veterans and their dependents; taking applications for state veterans' benefits including Chapter 115 financial benefits; helping veterans access employment assistance through career centers and related programs; and coordinating veteran observances including Memorial Day and Veterans Day. Such duties will be performed in the Office during regularly scheduled business hours or in the member Towns during office hours scheduled there.
3. **Chapter 115 Benefits:** It is understood and agreed that M.G.L. Chapter 115 benefits shall be billed directly to the member municipality where the veteran resides, and distribution of benefits payable to veterans in member municipalities under M.G.L. Chapter 115 shall be paid by the Treasurer of the member municipality in which that veteran resides.
4. **State/Federal Veterans’ Benefits Reimbursements:** It is understood and agreed that any reimbursements for veteran’s benefits from the Commonwealth of Massachusetts and/or the United States of America will be credited to the member municipality in which that veteran resides.
5. **Director:** The Veterans Services Officer of Agawam (“VSO”) shall serve as the director of veterans’ services for the District and shall supervise all staff in their duties.

6. **Board of Governors:** A Board of Governors comprised of the Mayor of Agawam (or his/her designee) and the Chairpersons of the Select Boards (or their designees) of the Towns of Southwick, Granville, Tolland and Russell. Each member shall have one vote on all matters that come before the Board. The Board shall approve the annual Administrative Budget for the District. The Board shall meet no less than once annually and shall comply with the Open Meeting Law and the Public Records Law.
7. **Treasurer:** The Treasurer/Collector of Agawam shall serve as the treasurer of the District and shall give to the District a bond, with a surety company authorized to transact business in the Commonwealth of Massachusetts as surety, for the faithful performance of the District Treasurer's duties in such sum and upon such conditions as said Board of Governors may require.
8. **Sharing of Costs:** The City and the Towns shall share the costs of the Western Hampden District Office on the basis of the taxable valuation of said municipalities as last established by the General Court. For Fiscal Year 2027, it shall be as follows:

Agawam	\$4,327,353,158	64.556%
Southwick	\$1,589,891,740	23.718%
Granville	\$288,585,230	4.305%
Tolland	\$266,796,477	3.980%
Russell	\$230,647,897	3.441%
Total	\$6,703,274,502	100%

9. **Coordination with Councils:** The Agawam Office shall work with local Veterans' Councils in the Veterans' Services Western Hampden District ("District") to assist with coordinating all ceremonies and parades in member communities.
10. **Compensation and Benefits:** The Director and any necessary administrative staff shall be employees of the City. The compensation and benefits for these positions shall be paid by the City, provided that the Towns agree to contribute to these costs via the District's Administrative Budget according to their annual assessments presented to the Board of Governors at its Annual Meeting, and pursuant to all parties' obligations under Paragraph 8 of this Agreement.
11. **Assessments:** Each municipality's annual assessment from the District shall be made payable to the City of Agawam, and mailed to the Treasurer/Collector at 36 Main Street, Agawam, MA 01001 no later than August 1st of each year.

12. **Indemnification:** Notwithstanding the final sentence Section 4A of Chapter 40 of the Massachusetts General Laws, the Towns shall indemnify and hold harmless Agawam, and each of its officials, officers, employees, agents, servants, and representatives (the Indemnities) from and against any claim arising from or in connection with the performance by the VSO of his/her duties in or for such Towns including, without limitation, any claim of liability, loss, damages, costs, and expenses for personal injury or damage to real or personal property by reason of negligent act or omission by the VSO while or in the performing services for such Towns. Such indemnification shall include, without limitation, current payment of all costs of defense (including reasonable attorneys' fees, expert witness fees, court costs, and related expenses) as and when such costs become due and the amounts of any judgments, awards and/or settlements, provided that (a) such Towns shall have the right to select counsel to defend against such claims, such counsel to be reasonably acceptable to Agawam and its insurer, if any, and to approve or reject any settlement with respect to which indemnification is sought, (b) the indemnitees shall cooperate with such Towns in all reasonable respect in connection with such defense, and (c) such Towns shall not be responsible to pay any judgment, award, or settlement to the extent occasioned by any acts of any of the indemnitees other than the VSO.

13. **Termination:** Participation in this Agreement may be terminated as to any party effective at the commencement of the next fiscal year. In order for a party to terminate its participation in this Agreement, written notice of termination must be received by each other party on or before February 1 preceding the commencement of the next fiscal year on July 1. Any notice received after February 1 shall not terminate this Agreement as to that party until the second subsequent fiscal year. No such termination shall affect any obligation of indemnification that may have arisen hereunder prior to such termination. The parties shall equitably adjust any payments made or due to relating to the unexpired portion of the Term following such termination.

14. **Assignment:** No party to this Agreement shall assign or transfer any of its rights or interests in or to this Agreement, or delegate any of its obligations hereunder, without the prior written consent of all other parties.

15. **Severability:** If any provision of this Agreement is held by a court of competent jurisdiction to be invalid, illegal, or unenforceable, or if any such term is so held when applied to any particular circumstance, such invalidity, illegality, or unenforceability shall not affect any other provision of this Agreement, or affect the application of such provision to any other circumstances, and this Agreement shall be construed and enforced as if such invalid, illegal, or unenforceable provision were not contained herein.

16. **Waiver:** The obligations and conditions set forth in this Agreement may be waived only by a writing signed by the party waiving such obligation or condition. Forbearance or indulgence by a party shall not be construed as a waiver, nor limit the remedies that would otherwise be available to that party under this Agreement or applicable law. No waiver of

any breach or default shall constitute or be deemed evidence of a waiver of any subsequent breach or default.

17. **Amendment**: This Agreement may only be amended by a writing signed by all parties duly authorized thereunto.
18. **Governing Law**: This Agreement shall be governed by and construed in accordance with the laws of the Commonwealth of Massachusetts.
19. **Headings**: The paragraph headings herein are for convenience only, are not part of this Agreement, and shall not affect the interpretation of this Agreement.
20. **Notices**: Any notice permitted or required hereunder to be given or served on any party by the other shall be in writing signed in the name of or on behalf of the party giving or serving the same. Notice shall be deemed to have been received at the time of the actual receipt of any in hand delivery or three (3) business days after the date of any properly addressed notice sent via the United States Post Office as set forth below:

- a. To Agawam: Any notice sent to Agawam hereunder shall be delivered in hand or sent by registered or certified mail, return receipt requested, postage prepaid, to:

Christopher C. Johnson, Mayor
Agawam City Hall
36 Main Street
Agawam, MA 01001

with a copy to:

Christopher S. Cappucci, Solicitor
Agawam Law Department
36 Main Street
Agawam, MA 01001

or to other such addresses as Agawam may designate in writing to the Towns hereafter.

- b. To Towns: Any notice to the Towns hereunder shall be delivered in hand or sent by registered or certified mail, return receipt requested, postage prepaid, to the Select Board of each such Town and to any other person designated in writing by such Town at the addresses listed below:

Town of Southwick
454 College Highway
Southwick, MA 01077

Town of Granville
707 Main Road/P.O. Box 247
Granville, MA 01034

Town of Tolland
241 West Granville Road
Tolland, MA 01034

Town of Russell
65 Main Street
Russell, MA 01071

21. Complete Agreement: This Agreement constitutes the entire Agreement between the parties concerning the subject matter hereof, superseding all prior agreements and understandings. There are no other agreements or understandings between the parties concerning the subject matter hereof. Each party acknowledges that it has not relied on any representations by the other party or by anyone acting or purporting to act for the other party or for whose actions the other party is responsible, other than the express, written representation set forth herein.
22. Financial Safeguards: The Director/VSO shall maintain separate, accurate, and comprehensive records of all services performed for each of the parties hereto. Agawam shall maintain accurate and comprehensive records of all costs incurred by or on account of the District, and all reimbursements and contributions received by it on behalf of the District. The Towns shall maintain separate, accurate, and comprehensive records of payments to Agawam. Any party may conduct an audit of the finances of the District and costs related thereto. Each party shall bear its own costs for conducting any audit.

For the City of Agawam

For the Town of Southwick

Date

Date

For the Town of Granville

For the Town of Tolland

Date

Date

For the Town of Russell

Date



Town of Agawam

Christopher C. Johnson, Mayor
36 Main Street
Agawam, MA 01001
Telephone: 413-786-0400 | 413-786-4520

Memorandum

To: Agawam City Council
From: Christopher C. Johnson, Mayor
Re: TR-2026-28 (Veterans District Inter-Municipal Agreement)
Date: April 16, 2026

The Town of Agawam has long been a part of the Western Hampden District Veterans Council along with the Towns of Granville, Russell, Southwick and Tolland. This arrangement benefits all communities by meeting each community's statutory obligation to employ a Veterans Service Officer, and by reducing the expenses of providing critical support for veterans in each community.

In researching the long standing relationship, we could find no guiding document that defined the operation of the Western Hampden District Veterans Council. In an effort to have the relationship clearly defined, the Veterans Council voted to establish an inter-municipal agreement. This is similar to virtually all the other veterans districts in the Commonwealth.

The attached agreement reflects the current practices that govern the Western Hampden District Veterans Council. The Veterans Service Officer and the assistant are employees of the Town of Agawam, and their office is located at the Senior Center on Main Street. They periodically hold office hours in the various communities to better serve veterans throughout the district.

The expenses of the Council are shared based upon the taxable valuation of the communities. Each community pays their proportionate share of the operating cost of the office, and each community is responsible for payment of any veterans benefits to veterans in their community. Agawam's share of the cost of operating the office is reflected in the Line Items section of the budget along with a separate line item for the payment of veterans benefits to veterans in Agawam.

The Agreement has been reviewed by all communities and each community is presently going through the process to approve it.

Please do not hesitate to contact me with any questions.

Very truly yours,

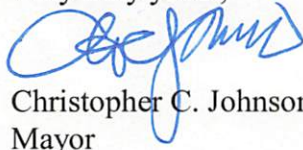
Christopher C. Johnson
Mayor

**A RESOLUTION SUPPORTING HOUSE BILL 5290 AND SENATE BILL 2285
WHICH ESTABLISH "ONE TOUCH MAKE READY APPLICATIONS" IN THE
COMMONWEALTH OF MASSACHUSETTS**

(Sponsored by Councilors Thomas Hendrickson and Rosemary Sandlin)

WHEREAS, competition is vital to the fair and equitable pricing and provision of internet and communication services in the Commonwealth of Massachusetts; and

WHEREAS, in order for there to be fair competition in the provision of internet and communication services in the Commonwealth of Massachusetts, the process for new companies to make attachments to existing utility poles and equipment needs to be updated and streamlined; and

WHEREAS, most states have adopted the "One Touch Make Ready Application" process for the determination of what work is required to make existing utility poles and equipment ready for new providers to attach their facilities and equipment; and

WHEREAS, the "One Touch Make Ready Application" process provides a streamlined and predictable process for new providers to gain access to existing utility poles and equipment which will increase competition in the provision of internet and communication services in the Commonwealth of Massachusetts; and

WHEREAS, H.5290, entitled "An Act to streamline broadband permitting and ensure equitable access to infrastructure" and S.2285, entitled "An Act to establish standards for the pole attachment process to facilitate the construction of broadband networks", have been filed with the General Court and call for the utilization of the "One Touch Make Ready Application" process in the Commonwealth of Massachusetts; and

WHEREAS, it is in the best interests of the City of Agawam to urge the adoption of H.5290 and S.2285; and

NOW THEREFORE, BE IT RESOLVED that the Agawam City Council hereby supports H. 5290 and S.2285 which call for the utilization of the "One Touch Make Ready Application" process in the Commonwealth of Massachusetts, and it further resolves to send a copy of this resolution to the Governor, our State Senator and our State Representatives.

Dated this ____ day of _____, 2026.

PER ORDER OF THE AGAWAM CITY COUNCIL

Anthony J. Russo, Council President

APPROVED AS TO FORM AND LEGALITY

Christopher S. Cappucci, Solicitor

HOUSE No. 5290

The Commonwealth of Massachusetts

HOUSE OF REPRESENTATIVES, March 25, 2026.

The committee on Telecommunications, Utilities and Energy, to whom were referred the petition (accompanied by bill, House, No. 3478) of Kip A. Diggs and Bud L. Williams relative to broadband permitting and access to infrastructure; and the petition (accompanied by bill, House, No. 3546) of Angelo J. Puppolo, Jr., for legislation to establish standards for the pole attachment process to facilitate the construction of broadband networks, reports recommending that the accompanying bill (House, No. 5290) ought to pass.

For the committee,

MARK J. CUSACK.

FILED ON: 3/18/2026

HOUSE No. 5290

The Commonwealth of Massachusetts

In the One Hundred and Ninety-Fourth General Court
(2025-2026)

An Act to streamline broadband permitting and ensure equitable access to infrastructure.

Be it enacted by the Senate and House of Representatives in General Court assembled, and by the authority of the same, as follows:

SECTION 1. Chapter 166 of the General Laws, as appearing in the 2024 Official Edition, is hereby amended by inserting after Section 25B the following new section:

Section 25C: Expedited Permitting, Access to Broadband Infrastructure, and Open Access Networks

(a) Purpose.

The purpose of this section is to accelerate broadband deployment across the Commonwealth, ensure fair and equitable access to critical infrastructure, prioritize open access network models, and establish best practices

for efficient permitting and construction processes.

(b) Definitions.

For the purposes of this section, the following terms shall have the following meanings:

1. **Broadband infrastructure:** Equipment or facilities necessary for broadband delivery, including poles, conduits, manholes, and wireless systems.
2. **Broadband provider:** Any entity engaged in deploying broadband services, including public, private, and non-profit organizations.
3. **Covered infrastructure:** Poles, conduits, manholes, and other facilities essential to broadband deployment.
4. **Legacy right-of-way agreement:** Any pre-existing agreement granting exclusive use of infrastructure to a single entity.
5. **Open access network:** A broadband network model in which physical infrastructure is shared by multiple service providers to promote competition, reduce deployment costs, and ensure equitable access to high-speed internet services.

(c) Commonwealth Priority for Open Access Networks.

1. The Commonwealth shall prioritize investment in and deployment of open access networks to ensure broadband infrastructure can support multiple service providers on fair and equitable terms.
2. Any state or municipal funding provided for broadband projects under this chapter shall require the recipient to implement an open access model for newly constructed infrastructure.
3. Public or non-profit broadband providers operating open access networks shall receive priority consideration for state funding and access to covered infrastructure.

(d) Non-Discriminatory Access to Covered Infrastructure.

1. All owners of covered infrastructure, including municipalities, private utilities, and telecommunications companies, shall grant broadband providers fair and timely access for the installation, maintenance, and operation of broadband infrastructure.

2. Requests for access must be approved or denied within 30 days of submission. Denials must include written justification and, where feasible, suggested alternatives.

3. Fees charged for access to covered infrastructure must be cost-based and transparent, with standards established by the Department of Telecommunications and Cable (DTC) within 180 days of enactment.

(e) Streamlined Permitting.

1. State and municipal permitting authorities shall process all broadband infrastructure permit applications within 45 days for standard projects and within 30 days for underserved or historic districts.

2. The Commonwealth shall develop and adopt a standardized permitting process applicable to all municipalities and state agencies to streamline broadband deployment.

(f) One-Touch Make-Ready (OTMR).

1. Pole owners must adopt OTMR procedures to allow broadband providers or contractors to perform all necessary work in a single coordinated operation.

2. OTMR work must comply with the National Electrical Safety Code (NESC) and state safety regulations.

3. The DTC shall establish a publicly accessible registry of qualified contractors authorized to perform OTMR work.

(g) "Dig Once" Policy.

1. Municipalities and state agencies may adopt a "Dig Once" policy, mandating the inclusion of empty conduits during all significant excavation projects to facilitate future broadband deployment.

2. Broadband providers shall be notified of planned excavation projects no fewer than 90 days in advance to coordinate installation efforts.

(h) Enforcement and Compliance.

1. The DTC shall oversee enforcement of this section and impose fines for non-compliance, up to \$25,000 per violation per day, with each day constituting a separate offense.

2. A broadband provider denied access or facing unreasonable permitting delays may appeal to the DTC, which shall resolve the matter within 30 days.

(i) Reporting Requirements.

The DTC shall submit an annual report to the General Court detailing:

1. The deployment progress of broadband infrastructure, particularly in underserved areas and economic development zones.

2. Progress in implementing open access networks statewide, including funded projects and their adherence to the open access model.

3. Compliance and enforcement actions taken under this section.

SECTION 2. Section 25C of chapter 166 of the General Laws, inserted by Section 1 of this act, shall not apply to railroad rights of way or any personal property located thereon.

SECTION 3. The provisions of this Act shall take effect 90 days after enactment.

BILL S.2285

194th (Current)

AN ACT TO ESTABLISH STANDARDS FOR THE POLE ATTACHMENT PROCESS TO FACILITATE THE CONSTRUCTION OF BROADBAND NETWORKS

By Mr. Gomez, a petition (accompanied by bill, Senate, No. 2285) of Adam Gomez for legislation to establish standards for the pole attachment process to facilitate the construction of broadband networks.

Bill Information

Presenter:

Adam Gómez

Status:

Referred to Senate Committee on Ways and Means

Summary:

This bill specifies procedures for contractors performing work to attach communication facilities to utility poles. Under the bill, pole owners can maintain lists of authorized contractors who meet qualifications. Entities requesting to attach to the poles can either choose from these lists or propose their own contractors, provided they meet the established qualifications. The bill introduces a "One Touch Make Ready" application process, setting a framework for submitting, evaluating, and approving pole attachment requests. It enforces timelines for reviewing applications and distinguishes between simple and complex make-ready work. The bill also outlines the management and notification processes required for conducting surveys and performing authorized attachments, detailing responsibilities, inspection opportunities, and remedies for damages incurred during the make-ready work.

** The bill summary was created by the Primary Sponsor of the bill; no committee of the General Court certifies the accuracy of its contents.*

The information contained in this website is for general information purposes only. The General Court provides this information as a public service and while we endeavor to keep the data accurate and current to the best of our ability, we make no representations or warranties of any kind, express or implied, about the completeness, accuracy, reliability, suitability or availability with respect to the website or the information contained on the website for any purpose. Any reliance you place on such information is therefore strictly at your own risk.

SENATE No. 2285

The Commonwealth of Massachusetts

PRESENTED BY:

Adam Gómez

To the Honorable Senate and House of Representatives of the Commonwealth of Massachusetts in General Court assembled:

The undersigned legislators and/or citizens respectfully petition for the adoption of the accompanying bill:

An Act to establish standards for the pole attachment process to facilitate the construction of broadband networks.

PETITION OF:

NAME:	DISTRICT/ADDRESS:	
<i>Adam Gómez</i>	<i>Hampden</i>	
<i>John F. Keenan</i>	<i>Norfolk and Plymouth</i>	<i>6/4/2025</i>
<i>John C. Velis</i>	<i>Hampden and Hampshire</i>	<i>7/14/2025</i>

SENATE No. 2285

By Mr. Gomez, a petition (accompanied by bill, Senate, No. 2285) of Adam Gomez for legislation to establish standards for the pole attachment process to facilitate the construction of broadband networks. Telecommunications, Utilities and Energy.

[SIMILAR MATTER FILED IN PREVIOUS SESSION
SEE SENATE, NO. 2133 OF 2023-2024.]

The Commonwealth of Massachusetts

In the One Hundred and Ninety-Fourth General Court
(2025-2026)

An Act to establish standards for the pole attachment process to facilitate the construction of broadband networks.

Be it enacted by the Senate and House of Representatives in General Court assembled, and by the authority of the same, as follows:

SECTION 1. Section 25A of Chapter 166 of the General Laws, as appearing in the 2022 Official Edition, is hereby amended by adding at the end of the eighth paragraph, after the words “used principally for the supply of electricity in bulk”, the following new sentence:-

“Notwithstanding the foregoing, attachments may be made pursuant to 25B of this chapter, or pursuant to order or regulation of the department.”

SECTION 2. Said Chapter 166 is hereby further amended by adding after Section 25A the following new section:-

Section 25B. One Touch Make Ready Applications

(a) The following terms as used in this section shall have the following meanings:

(1) “Abandoned Joint-Use Utility Pole”, means a joint-use utility pole from which all attachments have been removed.

(2) "Assigned space", means the space on a utility pole assigned by this Statute for the attachments of conductors or circuitry by joint-use entities, consistent with the provisions of the National Electrical Safety Code, Blue Book, or other reasonable practices. Assigned space does not include common space, including the communications worker safety zone. Space which may be available on a joint-use utility pole for an additional attaching entity must not be considered assigned space until an additional attachment is made, but must instead be considered common space.

(3) "Attaching entity", means a joint-use entity with an attachment to a joint-use utility pole.

(4) "Blue Book", means the "SR-1421, Blue Book – Manual of Construction Procedures" as published by Telcordia.

(5) "Common Space", means space of a joint-use utility pole used by all joint users in common and consists of the portion of a pole beneath ground level, the portion from ground level to the lowest place on the pole at which a telecommunications circuit may be attached, plus all but 6 inches of the telecommunications worker safety zone. The common space is equal to the length of the pole minus the assigned spaces for each attaching entity. In addition, for the purpose of assigning and allocating space and costs on a joint-use utility

pole, space which may be available for an additional attachment, and which would become assigned space if an additional attachment were made, must be considered common space until such an attachment is made.

(6) "Complex make-ready", means any make ready work above the communications space; transfers and work within the communications space that would be reasonably likely to cause a service outage or facility damage, including the splicing of any communication attachment or relocation of an existing wireless attachment; and the replacement of a joint-use utility pole. Any and all wireless activities, including those involving mobile, fixed, and point-to-point wireless communications and wireless.

(7) "Communications space", means the portion on a joint-use utility pole that begins at the bottom of the communications worker safety zone and ends at the lowest point above grade to which a horizontal communications wire can be attached consistent with the National Electrical Safety Code.

(8) "Communication worker safety zone", means a 40-inch vertical space, or other amount as required by the National Electrical Safety Code for the purpose of safety, on which no electric or communications circuitry may be attached. The zone is located between the areas to which electric conductors and communication circuitry may be attached. All but six inches of the "communications worker safety zone" must be considered part of the common space of a utility pole.

(9) "Information service provider", means a provider of "information service" as defined in Title 47 of the United States Code.

(10) "Joint-use entity", means a utility, licensee, or wireless provider.

(11) "Joint-use utility pole" is a utility pole on which there are circuit or electric conductor attachments by an electric utility and attachments by one or more joint-use entities. Joint-use utility poles do not include poles whose sole purpose is supporting electrical transmission conductors as defined by the Federal Energy Regulatory Commission. However, if an electric utility under-builds a transmission line with distribution, those poles are considered joint-use utility poles.

(12) "Licensee", means any person, firm or corporation other than a utility, which is authorized to construct lines or cables upon, along, under and across the public ways. For the purposes of this section, the term shall also include a municipal lighting plant or cooperative that operates a telecommunications system outside

the limits of its service territory pursuant to section 47E of chapter 164, but only for those attachments that are outside its service territory.

(13) "Make-ready work" or "make-ready", means the modification or replacement of a joint-use utility pole, or of the lines or equipment on the joint-use utility pole, to accommodate additional facilities on the joint-use utility pole.

(14) "National Electric Safety Code" or "NESC", means published by the Institute of Electrical and Electronics Engineers and approved by the American National Standards Institute Code C2.

(15) "Overlash", means the tying or lashing of additional communications wires, cables, and facilities to existing communications wires, cables, or supporting strand already attached to poles.

(16) "Pole attachment" or "attachment", means the physical connection of a facility that a joint-use entity uses to provide communications or electric service.

(17) "Pole owner", means an entity that owns or jointly owns a joint-use utility pole, or controls usable space on a joint-use utility pole.

(18) "Replaced joint-use utility pole", means a joint-use utility pole that has been replaced by a new joint-use utility pole. Once the last attachment has been removed from the pole, the pole becomes an abandoned joint-use utility pole.

(19) "Requesting party", means a utility or joint-use entity that is seeking to place attachments on joint-use utility poles.

(20) "Simple make-ready", means make-ready work where existing attachments in the communications space of a joint-use utility pole can be transferred without any reasonable expectation of a service outage or facility damage and where the transfer does not require splicing of any existing communication attachment or relocation of an existing wireless attachment. Simple make ready does not apply to attachments above the communications space or pole replacements.

(21) "Usable Space", means the space on a joint-use utility pole above the minimum grade level which can be used for the attachment of wires, cables, and associated equipment.

(22) "Utility", means any person, firm, corporation or municipal lighting plant that owns or controls or shares ownership or control of poles, ducts, conduits or rights of way used or useful, in whole or in part, for supporting or enclosing wires or cables for the transmission of intelligence by telegraph, telephone or television or for the transmission of electricity for light, heat or power.

(23) "Wireless provider", means any city or town incorporated in the commonwealth, person, firm, or corporation which provides telecommunications service. A utility shall not be considered a wireless provider for the purposes of this section.

(b) Qualified Contractors:

(1) A pole owner may make available a list of contractors it authorizes to perform surveys and make-ready in the communications space on its utility poles in cases involving One Touch Make-Ready under Subsection (c) of this Section. Listed contractors must be trained to work with coaxial and fiber optic cable and be reasonably insured or bonded.

(2) If a requesting party hires a contractor for purposes specified in Subsection (c) of this Section, the requesting party may choose from the pole owner's list of authorized contractors or request the addition to the pole owner's authorized contractor list any contractor that meets the minimum qualifications in Subsection (b)(5) of this Section, and the pole owner may not unreasonably deny such a request.

(3) If a pole owner does not provide a list of approved contractors for surveys or simple make-ready or no contractor on the pole owner's contractor list is available within a reasonable time period then the requesting party may choose its own qualified contractor that meets the requirements in Subsection (b)(5) of this Section. When choosing a contractor that is not on the pole owner's list, the requesting party must certify to pole owner that its contractor meets the minimum qualifications described in Subsection (b)(5) of this Section when providing notices required by Subsection (c) of this Section.

(4) A pole owner may disqualify any contractor chosen by a requesting party that is not on the pole owner's contractor list, but such disqualification must be based on reasonable safety or reliability concerns related to the contractor's failure to meet any of the minimum qualifications described in Subsection (b)(5) of this Section or to meet the pole owner's publicly available and commercially reasonable safety or reliability standards. The pole owner must provide notice of its contractor objection within the notice requirements of Subsection (c) of this Section and in its objection must identify at least one available qualified contractor.

(5) In addition to the requirements in Subsection (b)(1) of this Section, pole owners must ensure that contractors on their lists as described in this Section, and requesting parties must ensure that contractors they select pursuant to Subsection (b)(3) of this Section, meet the following minimum requirements:

(6) The contractor has agreed to follow published safety and operational guidelines of the pole owner, if available, but if unavailable, the contractor shall agree to follow National Electrical Safety Code guidelines;

(7) The contractor has acknowledged that it knows how to read and follow licensed-engineered pole designs for make-ready, if required by the pole owner;

(8) The contractor has agreed to follow all local, state, and federal laws and regulations including, but not limited to, the rules regarding Qualified and Competent Persons under the requirements of the Occupational and Safety Health Administration rules; and

(9) The contractor has agreed to meet or exceed any uniformly applied and reasonable safety and reliability thresholds set by the pole owner, if made available.

(10) A requesting party that hires a contractor for survey or make-ready work must provide a pole owner or affected attaching entity with a reasonable opportunity for a representative to accompany and consult with the authorized contractor and the requesting party.

(11) The consulting representative of an electric utility may make determinations, on a nondiscriminatory basis, where there is insufficient capacity and for reasons of safety, reliability, and generally applicable engineering purposes.

(c) One touch make ready application process

(1) **One Touch Make-Ready Option for Simple Make-Ready:** For attachments involving simple make-ready, a requesting party may elect to proceed with the process described in this Subsection. It is the responsibility of the requesting party to ensure that its contractor determines whether the make-ready requested in an attachment application is simple make-ready.

(i) An application for attachment must be submitted in writing and must provide the pole owner with the information necessary to grant or deny the application.

(ii) A requesting party electing the one touch make-ready option must indicate that it intends to perform one-touch make-ready in its attachment application and must identify the simple make-ready it will perform.

(iii) A pole owner must review the requesting party's attachment application for completeness before reviewing the application on its merits. An attachment application is considered complete if it provides the pole owner with the information necessary under its procedures, as specified in a master service agreement or in publicly-released requirements at the time of submission of the application, to make an informed decision on the application.

(iv) A pole owner must complete its review for completeness within 10 business days of receipt of the application and notify the requesting party of that decision. If the pole owner does not respond within 10 business days after receipt of the application, or if the pole owner rejects the application as incomplete but fails to specify any reasons in the application, then the application is deemed complete.

(v) If the pole owner timely notifies the requesting party that its attachment application is not complete, then the pole owner must specify all reasons for finding it incomplete. Any resubmitted application need only address the pole owner's reasons for finding the application incomplete and must be deemed complete within 5 business days after its resubmission, unless the pole owner specifies to the requesting party which reasons were not addressed and how the resubmitted application did not sufficiently address the reasons. The requesting party may follow the resubmission procedure in this paragraph as many times as it chooses so long as in each case it makes a bona fide attempt to correct the reasons identified by the pole owner, and in each case the deadline set forth in this paragraph shall apply to the utility's review.

(vi) The pole owner shall review on the merits a complete application requesting one-touch make-ready and respond to the requesting party either granting or denying an application within 30 days of the pole owner's receipt of a complete application.

(vii) If the pole owner denies the application on its merits, then its decision shall be specific, shall include all relevant evidence and information supporting its decision, and shall explain how such evidence and information relate to a denial of access for reasons of lack of capacity, safety, reliability, or engineering standards.

(viii) Within the 30-day application review period, a pole owner may object to the designation by the requesting party's contractor that certain make-ready is simple. If the pole owner objects to the contractor's

determination that make-ready is simple, then it is deemed complex. The pole owner's objection is final and determinative so long as it is specific and in writing, includes all relevant evidence and information supporting its decision, made in good faith, and explains how such evidence and information relate to a determination that the make-ready is not simple.

(2) Surveys. The requesting party is responsible for all surveys required as part of the one-touch make-ready process and must use a contractor that is appropriately trained and licensed as well as reasonably insured or bonded and otherwise meets the requirements of Subsection (b)(5) of this Section.

(i) A requesting party may need to perform a survey to determine whether the necessary make-ready work is simple or complex before filing an application for one-touch make-ready.

(ii) The requesting party must permit the pole owner and any affected attaching entity to be present for any field inspection conducted as part of the requesting party's surveys. The requesting party must use commercially reasonable efforts to notify the pole owner and any affected attaching entities three business days before a field inspection as part of any survey and must provide the date, time, and location of the surveys, and the name of the contractor performing the surveys.

(3) Make-Ready. If the pole owner approves the requesting party's attachment application and if the requesting party has provided 15 calendar days' prior written notice of the make-ready to the pole owner and affected attaching entities, the requesting party may proceed with make-ready using a contractor that is appropriately trained and licensed as well as reasonably insured or bonded and otherwise meets the requirements of Subsection (b)(5) of this Section.

(i) The prior written notice must include the date and time of the make-ready work, a description of the work involved, and the name of the contractor being used by the requesting party and must provide the pole owner and any affected attaching entities a reasonable opportunity to be present for any make-ready work.

(ii) The requesting party must immediately notify a pole owner or affected attaching entity if the make-ready work damages any equipment or causes an outage that is reasonably likely to interrupt service. Upon receiving notice from the requesting party, the pole owner or affected attaching entity may either: Complete any necessary remedial work and bill the requesting party for the reasonable costs related to fixing the damage or require the requesting party to fix the damage at its expense immediately following notice from the pole owner or affected attaching entity.

(iii) In performing make-ready work, if the requesting party, the pole owner, or an affected attaching entity determines that any work classified as simple make-ready is actually complex make-ready, then that specific make-ready work must be halted, and the determining party must provide immediate notice to the other parties of its determination and the affected poles. The affected make-ready will then be completed by the responsible party as soon as reasonably practicable.

(4) Post-Make-Ready Timeline. A requesting party must notify the pole owner and any affected attaching entities with notice of the completion of the make-ready work within 15 calendar days of completion. Such notice must provide the pole owner and any affected attaching entities 90 calendar days from receipt of the notice to inspect the make-ready work, and that the pole owner and any affected attaching entities have 14 calendar days from the completion of their inspection to notify the requesting party of any damage or code violation resulting from the make-ready work. The pole owner or affected attaching entity may either complete any necessary remedial work and bill the requesting party for reasonable costs associate with the remediation or require the requesting party to perform the remediation at the requesting party's expense within 14 calendar days of notification.

TR-2026-30

**A RESOLUTION TO APPROPRIATE FUNDS FOR
THE SUCCESSOR COLLECTIVE BARGAINING AGREEMENT
BY AND BETWEEN THE AGAWAM DEPARTMENT OF PUBLIC WORKS
EMPLOYEES' ASSOCIATION AND THE TOWN OF AGAWAM**

(Sponsored by Christopher C. Johnson, Mayor)

WHEREAS, the Town of Agawam has negotiated a successor collective bargaining agreement with the Agawam Department of Public Works Employees' Association which is memorialized in the document entitled Settlement Agreement by and between the Town of Agawam and the Agawam Department of Public Works Employees' Association (hereinafter referred to as the "Settlement Agreement"); and

WHEREAS, the Settlement Agreement has been ratified by the Agawam Department of Public Works Employees' Association; and

WHEREAS, the Settlement Agreement is a three year agreement for the period of July 1, 2025 to June 30, 2028 that provides for the following annual cost of living increases: effective July 1, 2025 (2.5% percent increase); effective July 1, 2026 (2.5% increase); and effective July 1, 2027 (3.0% increase); and

WHEREAS, pursuant to Massachusetts General Laws Chapter 150E, Section 7, the Agawam City Council is required to appropriate the necessary funds; and

WHEREAS, funding for the Agreement was approved as part of the Fiscal Year 2026 Annual Operating Budget and shall be transferred to various salary line items from the Salary Reserve line items in the Water and Wastewater Department budgets and the Salary Reserve Account in the Line Items section of the Fiscal Year 2026 Annual Operating Budget; and

WHEREAS, it is in the best interests of the Town of Agawam to appropriate the necessary funds for the successor collective bargaining agreement by and between the Town of Agawam and the Agawam Department of Public Works Employees' Association; and

NOW THEREFORE, BE IT RESOLVED BY THE AGAWAM CITY COUNCIL that the sum of Sixty-Nine Thousand One Hundred Ninety-Five and 00/100 (\$69,195.00) Dollars shall be appropriated from the Salary Reserve line items in the Water and Wastewater Department budgets and the Salary Reserve Account in the Line Items section of the Fiscal Year 2026 Annual Operating Budget to be transferred to various salary line items to fund the first year of the successor collective bargaining agreement with the Agawam Department of Public Works Employees' Association entitled Settlement Agreement by and between the Town of Agawam and the Agawam Department of Public Works Employees' Association, a copy of which is attached hereto and incorporated herein by reference.

Dated this ____ day of _____, 2026.

PER ORDER OF THE AGAWAM CITY COUNCIL

Anthony J. Russo, President

APPROVED AS TO FORM AND LEGALITY

Christopher S. Cappucci, City Solicitor

APPROVED AS TO APPROPRIATION

Cheryl St. John, Auditor

BUDGETARY TRANSFER FORM

Department: Line Items/Water Department/Wastewater Department

Amount: \$ 69,195.00 Date: April 16, 2026

From	Line Items – Salary Reserve	16605 57350	\$ 45,249.00
	Water Dept – Salary Reserve	60141 57350	\$ 17,167.00
	Wastewater Dept – Salary Reserve	22541 57350	\$ 6,779.00
	Total		\$ 69,195.00

Title of Account	Acct Number	Amount
------------------	-------------	--------

To	DPW Admin Regular Permanent	14001 51010	\$ 2,119.00
	Highway Regular Permanent	14201 51010	\$ 32,736.00
	Highway Overtime	14201 51030	\$ 1,375.00
	Motor Vehicle Regular Permanent	14901 51010	\$ 2,952.00
	Motor Vehicle Overtime	14901 51030	\$ 194.00
	Engineering Regular Permanent	14101 51010	\$ 5,848.00
	Engineering Overtime	14101 51030	\$ 25.00
	Water Regular Permanent	60141 51010	\$ 15,475.00
	Water Overtime	60141 51030	\$ 1,692.00
	Wastewater Regular Permanent	22541 51010	\$ 5,764.00
	Wastewater Overtime	22541 51030	\$ 1,015.00
	Total		\$ 69,195.00

Title of Account	Acct Number	Amount
------------------	-------------	--------

Reason for Transfer: To fund first year of new collective bargaining agreement with Agawam Department of Public Works Employees' Association

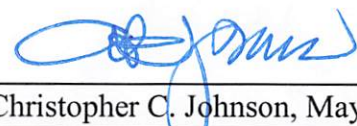

Christopher C. Johnson, Mayor

I hereby certify that funds are available to make the above-stated transfer.

Date: _____

Cheryl St. John, Auditor

I hereby approve placement of the above-stated transfer on the Council agenda.

Date: 04-16-2026

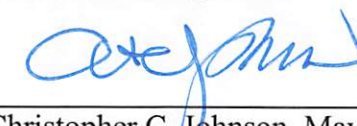

Christopher C. Johnson, Mayor

Approved as to Form and Legality.

Date: _____

Christopher S. Cappucci, Solicitor

PER ORDER OF THE AGAWAM TOWN COUNCIL – APPROVED ON _____, 20__

Date: _____

Anthony J. Russo, President

APPROVAL OF LEGISLATION: Pursuant to Section 3-6 of the Agawam Home Rule Charter, I hereby approve the Council passage of the above-stated transfer (TO-2026-5).

Date: _____

Christopher C. Johnson, Mayor

DISAPPROVAL OF LEGISLATION: Pursuant to Section 3-6 of the Agawam Home Rule Charter, I hereby disapprove the Council passage of the above-stated transfer (TO-2026-5) for the following reasons:

Date: _____

Christopher C. Johnson, Mayor

RETURN OF LEGISLATION TO COUNCIL CLERK

Returned to Council Clerk on this _____ day of _____, 2026.